

# INSTRUCTION BOOK

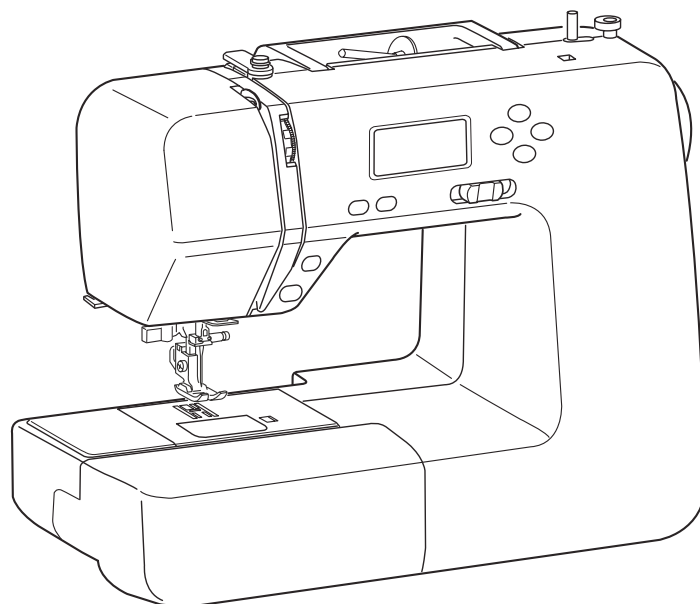

# IMPORTANT SAFETY INSTRUCTIONS

When using an electrical appliance, basic safety precautions should always be followed, including the following:

This sewing machine is designed and manufactured for household use only.

Read all instructions before using this sewing machine.

## **DANGER** — To reduce the risk of electric shock:

1. An appliance should never be left unattended when plugged in. Always unplug this sewing machine from the electric outlet immediately after using and before cleaning.

## **WARNING** — To reduce the risk of burns, fire, electric shock, or injury to persons:

1. Do not allow to be used as a toy. Close attention is necessary when this sewing machine is used by or near children.
2. Use this appliance only for its intended use as described in this owner's manual. Use only attachments recommended by the manufacturer as contained in this owner's manual.
3. Never operate this sewing machine if it has a damaged cord or plug, if it is not working properly, if it has been dropped or damaged, or dropped into water. Return this sewing machine to the nearest authorized dealer or service center for examination, repair, electrical or mechanical adjustment.
4. Never operate the appliance with any air opening blocked. Keep ventilation openings of this sewing machine and foot controller free from accumulation of lint, dust and loose cloth.
5. Never drop or insert any object into any opening.
6. Do not use outdoors.
7. Do not operate where aerosol (spray) products are being used or where oxygen is being administered.
8. To disconnect, turn all controls to the off ("O") position, then remove plug from outlet.
9. Do not unplug by pulling on cord. To unplug, grasp the plug, not the cord.
10. Keep fingers away from all moving parts. Special care is required around the sewing machine needle and/or cutting blade.
11. Always use the proper needle plate. The wrong plate can cause the needle to break.
12. Do not use bent needles.
13. Do not pull or push fabric while stitching. It may deflect the needle causing it to break.
14. Switch this sewing machine off ("O") when making any adjustment in the needle area, such as threading the needle, changing the needle, threading the bobbin or changing the presser foot, and the like.
15. Always unplug this sewing machine from the electrical outlet when removing covers, lubricating, or when making any other adjustments mentioned in this owner's manual.

## SAVE THESE INSTRUCTIONS

### **For Europe only:**

This appliance can be used by children aged from 8 years and above and persons with reduced physical, sensory or mental capabilities or lack of experience and knowledge if they have been given supervision or instruction concerning use of the appliance in a safe way and understand the hazards involved. Children shall not play with the appliance. Cleaning and user maintenance shall not be made by children without supervision.

### **For outside Europe (except U.S.A and Canada):**

This appliance is not intended for use by persons (including children) with reduced physical, sensory or mental capabilities, or lack of experience and knowledge, unless they have been given supervision or instruction concerning use of the appliance by a person responsible for their safety.

Children should be supervised to ensure that they do not play with the appliance.



Please note that on disposal, this product must be safely recycled in accordance with relevant National legislation relating to electrical/electronic products. If in doubt please contact your retailer for guidance. (European Union only)

## TABLE OF INSTRUCTION

### SECTION I. NAMES OF PARTS

Names of Parts.....	2
Standard Accessories .....	3
Extension Table .....	3

### SECTION II. GETTING READY TO SEW

Connecting the Power Supply .....	4
Before Using Your Sewing Machine.....	4
Speed Control Slider .....	5
Controlling Sewing Speed .....	5
Machine Operating Buttons.....	6-7
Removing and Attaching the Foot Holder.....	8
Changing the Presser Foot.....	8
Presser Foot Lifter .....	8
Dropping or Raising the Feed Dog .....	9
Changing the Needle.....	9
Selecting Thread and Needles .....	9
Bobbin Winding.....	10-12
Threading the Machine.....	13
Needle Threader.....	14
Drawing up the Bobbin Thread .....	15
LCD Display.....	16
Stitch Patterns .....	16
Adjusting the Needle Thread Tension for a Straight Stitch .....	17
Adjusting the Needle Thread Tension for a Zigzag Stitch.....	18

### SECTION III. BASIC SEWING

Straight Stitch Sewing .....	19
Needle Plate .....	20
Straight Stitch .....	21
Lock-a-Matic Stitch .....	21
Locking Stitch .....	21
Stretch Stitch .....	21
Triple Stretch Stitch.....	22
Sculpture Stitch .....	22
Saddle Stitch .....	22
Zigzag Stitch.....	23
Multiple Zigzag .....	24
Knit Stitch .....	24
Overedge Stitch.....	24
Various Kinds of Buttonholes and Their Uses .....	25
Square Buttonhole.....	26-27
Adjusting the Stitch Width and Density for Buttonholes.....	28
Round-End Buttonhole .....	28
Keyhole Buttonhole.....	28
Corded Buttonhole.....	29
Darning Stitch.....	30
Tacking .....	31
Eyelet.....	31
Zipper Sewing.....	32-33
Blind Hemming .....	34
Button Sewing .....	35
Shelltuck Stitch .....	35
Applique.....	36

### SECTION IV. DECORATIVE STITCHING

Scallop Stitch.....	36
Smocking.....	37
Patchwork Piecing .....	37
Fagoting.....	38
Satin Stitches.....	38
Cross Stitch .....	39
Decorative Stitches.....	39
Decorative Stitch Combinations .....	40
Correcting Distorted Stitch Patterns .....	40

### SECTION V. CARE OF YOUR MACHINE

Cleaning the Hook Race and Feed Dog.....	41
Installing the Bobbin Holder.....	41
Problems and Warning Signs .....	42
Troubleshooting .....	43

## SECTION I. NAMES OF PARTS

### Names of Parts

- ① Extension table (Accessory box)
- ② Needle plate
- ③ Needle threader
- ④ Thread cutter
- ⑤ Face cover
- ⑥ Thread take-up lever
- ⑦ Thread tension dial
- ⑧ Spool pin
- ⑨ Large spool holder
- ⑩ Bobbin winder spindle
- ⑪ Bobbin winder stopper
- ⑫ Hole for additional spool pin
- ⑬ Value set buttons
- ⑭ Cursor buttons
- ⑮ LCD display
- ⑯ Speed control slider
- ⑰ Needle up/down button
- ⑱ Auto-lock button
- ⑲ Reverse stitch button
- ⑳ Start/stop button
- ㉑ Hook cover plate
- ㉒ Presser foot (Zigzag foot A)
- ㉓ Foot holder
- ㉔ Needle clamp screw
- ㉕ Needle
- ㉖ Hook cover release button
- ㉗ Power inlet
- ㉘ Foot control jack
- ㉙ Power switch
- ㉚ Handwheel
- ㉛ Carrying handle
- ㉜ Upper thread guide
- ㉝ Presser foot lifter
- ㉞ Buttonhole lever
- ㉟ Free-arm
- ㊱ Drop feed lever
- ㊲ Foot control
- ㊳ Power supply cord

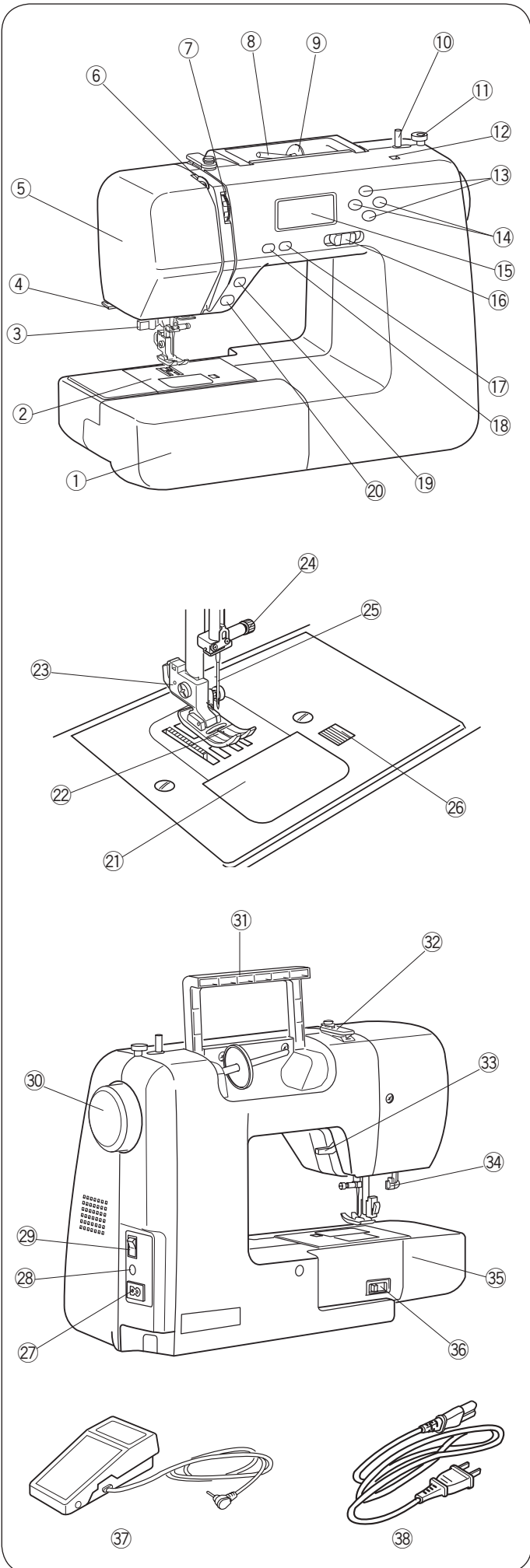

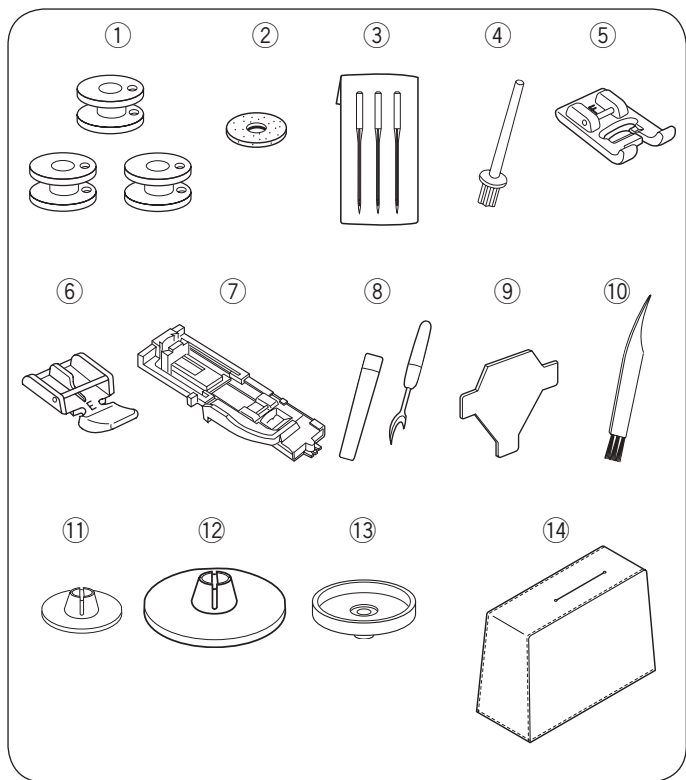

### Standard Accessories

- ① Bobbin
- ② Spool pin felt
- ③ Needle set
- ④ Additional spool pin
- ⑤ Satin stitch foot F
- ⑥ Zipper foot E
- ⑦ Automatic buttonhole foot R
- ⑧ Seam ripper (Buttonhole opener)
- ⑨ Screwdriver key
- ⑩ Lint brush
- ⑪ Small spool holder
- ⑫ Large spool holder
- ⑬ Spool stand
- ⑭ Soft cover

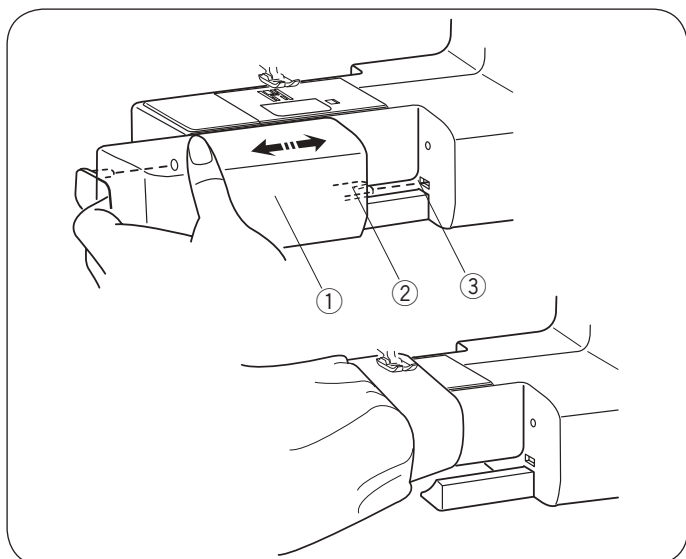

### Extension Table

The extension table ① provides an extended sewing area and can be easily removed for free arm sewing.

- ① Extension table
- ② Tab
- ③ Slot

#### • Detaching the table

Pull the table away from the machine, as illustrated.

#### • Attaching the table

Push the extension table, inserting the tab ② into the slot ③ until the table snaps into the machine.

#### • Free-arm sewing

Free-arm sewing is useful for darning socks or mending knees, cuffs or areas of wear in children's clothes.

## SECTION II. GETTING READY TO SEW

### Connecting the Power Supply

#### • Using the foot control

Turn off the power switch ①.  
Insert the foot control plug ② into the foot control jack ③.  
Insert the machine plug ④ into the power inlet ⑤.  
Insert the power supply plug ⑥ into the wall outlet ⑦.  
Turn on the power switch ①.  
The foot control sign ⑧ will be displayed when the foot control is connected to the machine.

- ① Power switch
- ② Foot control plug
- ③ Foot control jack
- ④ Machine plug
- ⑤ Power inlet
- ⑥ Power supply plug
- ⑦ Wall outlet
- ⑧ Foot control sign

#### • Using the start/stop button

Turn off the power switch ①.  
Insert the machine plug ② into the power inlet ③.  
Insert the power supply plug ④ into the wall outlet ⑤.  
Turn on the power switch ①.

- ① Power switch
- ② Machine plug
- ③ Power inlet
- ④ Power supply plug
- ⑤ Wall outlet

#### NOTE:

The start/stop button does not work when the foot control is connected.



#### WARNING:

While in operation, always keep your eyes on the sewing area, and do not touch any moving parts such as the thread take-up lever, handwheel or needle.

Always turn off the power switch and unplug from the power supply:

- when leaving the machine unattended.
- when attaching or removing parts.
- when cleaning the machine.

Do not place anything on the foot control, otherwise the machine will run inadvertently.

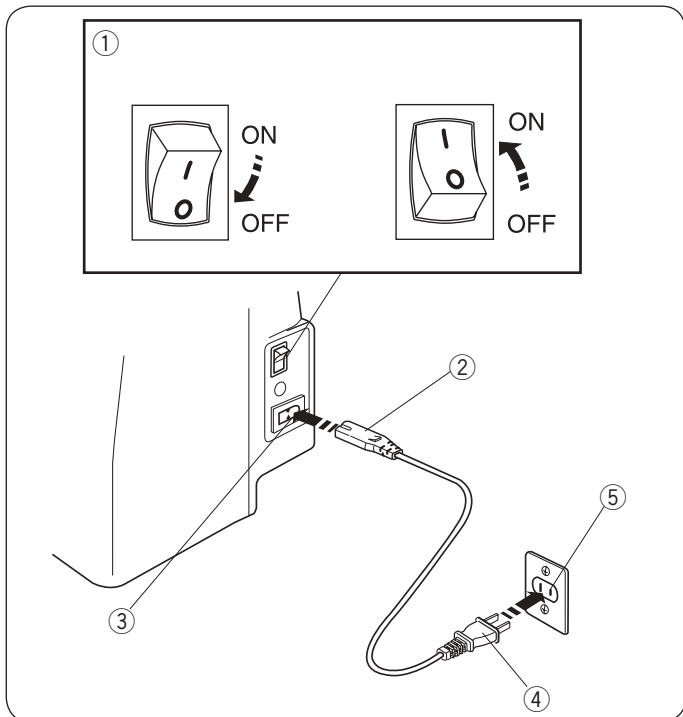
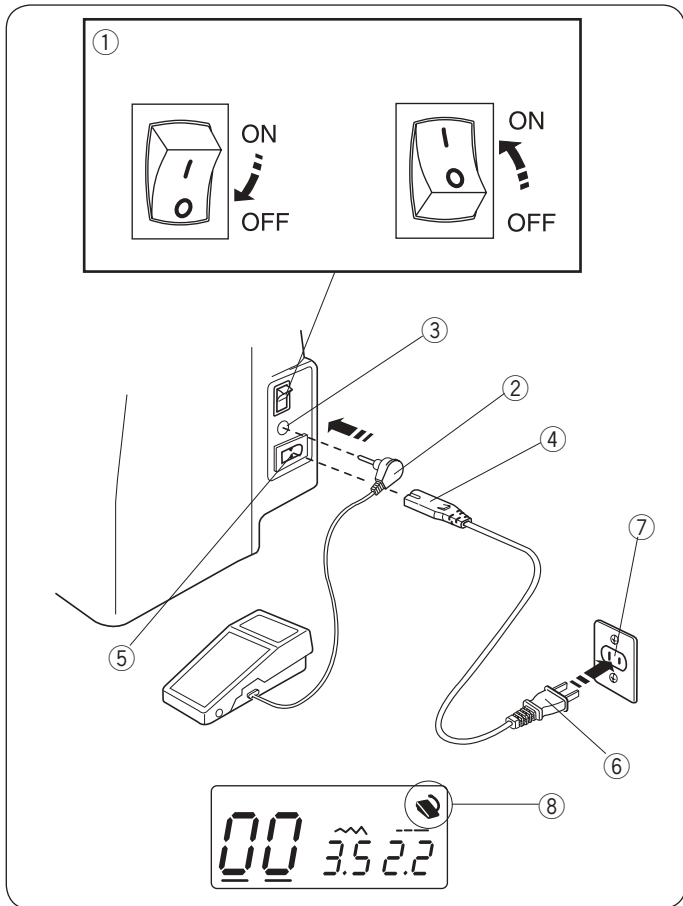

#### Operating Instructions:

The symbol "O" on a switch indicates the "off" position of a switch.

For appliances with a polarized plug (one blade wider than the other): To reduce the risk of electric shock, this plug is intended to fit in a polarized outlet only one way. If it still does not fit, contact a qualified electrician to install the proper outlet. Do not modify the plug in any way (U.S.A. and Canada only).

\* Foot control model YC-485EC-1 is used with this sewing machine.

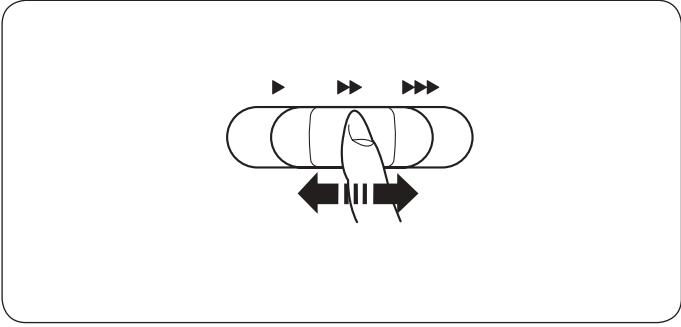

### **Speed Control Slider**

Sewing speed can be varied by the speed control slider according to your sewing needs.  
To increase sewing speed, slide the slider to the right.  
To decrease sewing speed, slide the slider to the left.

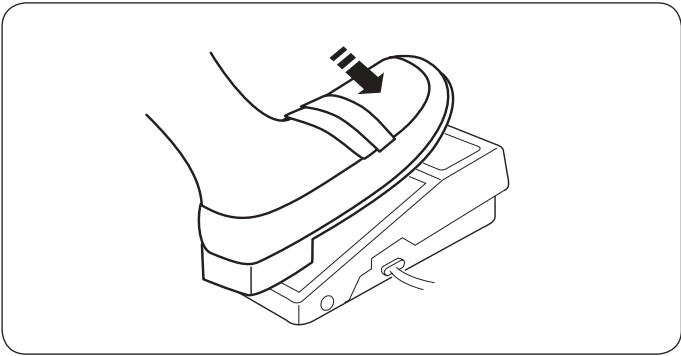

### **Controlling Sewing Speed**

Depress the foot control to start the machine.  
The further down you press on the foot control, the faster the machine runs.  
The maximum sewing speed can be varied by the speed control slider.

## Machine Operating Buttons

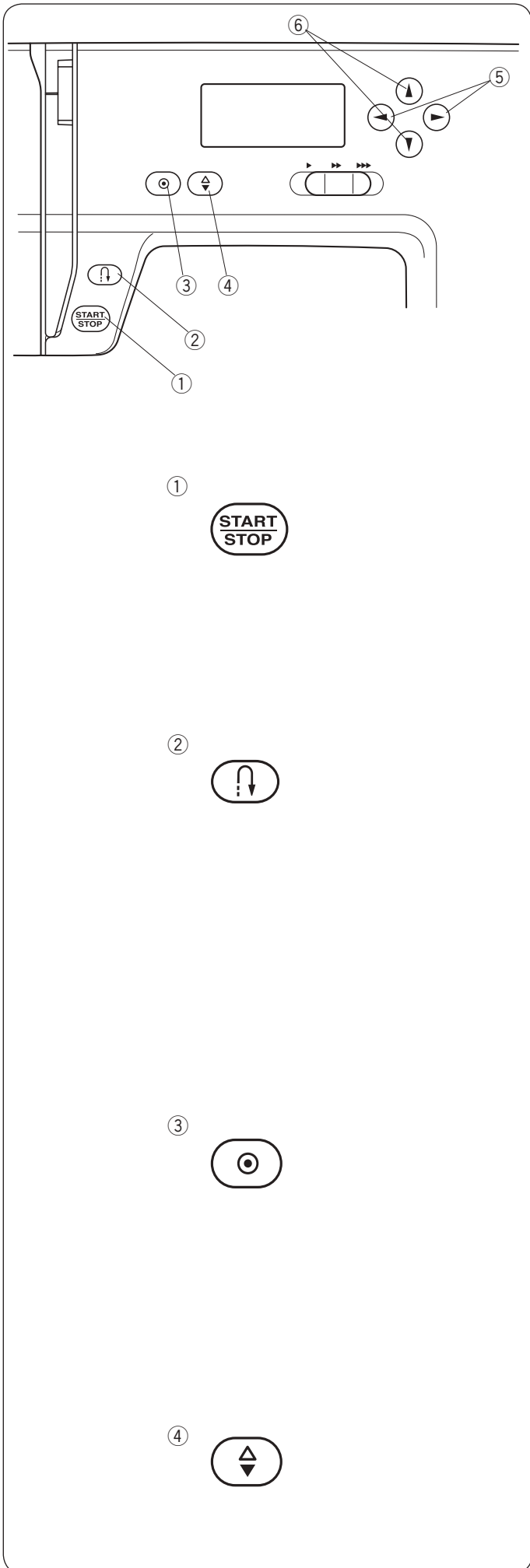

### ① Start/Stop Button

Lower the presser foot lifter.

Press the start/stop button ① to start the machine.

The machine starts running slowly for the first few stitches; it then runs at the speed set by the speed control slider.

Press the start/stop button ① again to stop the machine.

#### NOTES:

- The machine runs slowly as long as you press and hold the start/stop button ①.
- The start/stop button ① cannot be used when the foot control is connected to the machine.

### ② Reverse Stitch Button

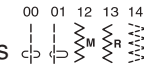
When stitches  (00, 01, 12, 13, 14) are selected, the machine will sew in reverse while the reverse stitch button is pressed.

If you press the reverse stitch button when sewing any other stitches, the machine will immediately sew locking stitches and automatically stop.

If you press the reverse stitch button when stitch pattern 00, 01, 12, 13 or 14 is selected and the foot control is not connected, the machine will sew in reverse as long as the button is pressed, and the machine will stop when the button is released.

### ③ Auto-lock Button

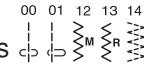
When stitches  (00, 01, 12, 13, 14) are selected, the machine will immediately sew locking stitches and automatically stop when the auto-lock button is pressed.

If you press the auto-lock button when sewing any other stitches, the machine will sew locking stitches at the end of the current pattern and automatically stop.



### ④ Up/down Needle Position Button

Press this button to bring the needle up or down.

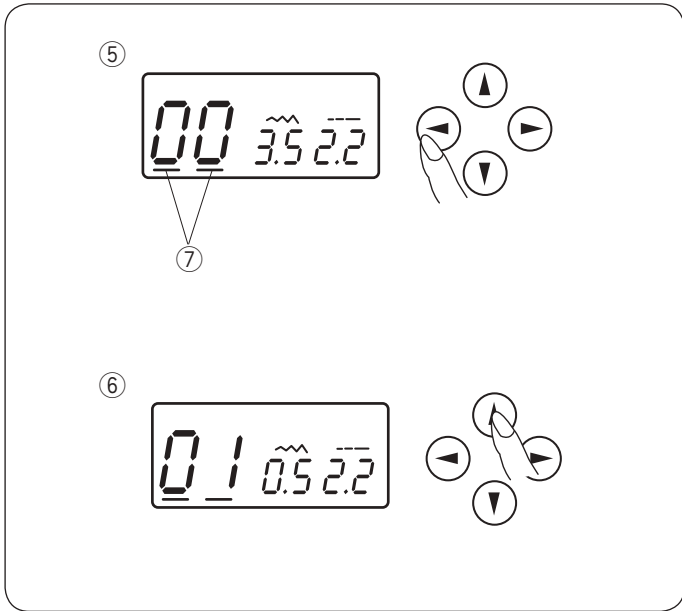

The machine will stop with the needle up or down depending on the needle position determined by this button.



**⑤ Cursor Buttons**

Use these buttons to move the cursor ⑦.  
Press  button to move the cursor to right.  
Press  button to move the cursor to left.

**⑥ Value Set Buttons**

Use these buttons to change the set value.  
Move the cursor under the digit you would like to change.  
Press  button to increase the value.  
Press  button to decrease the value.

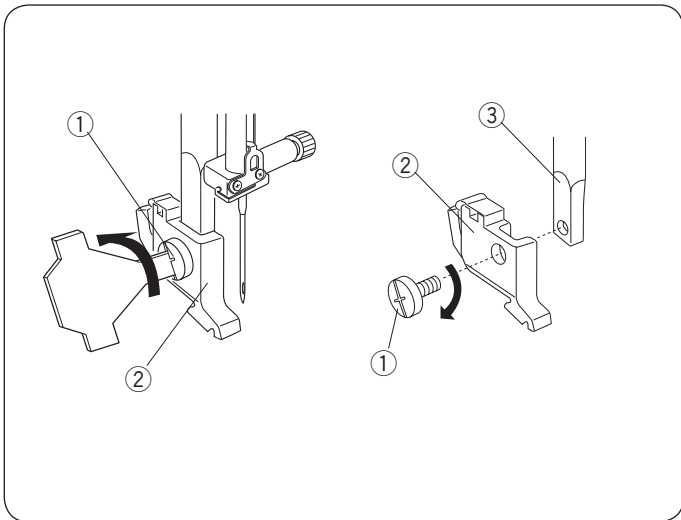

## Removing and Attaching the Foot Holder

### **⚠ CAUTION:**

Turn OFF the power switch before detaching or attaching foot holder.

- **Removing the foot holder**

Remove the setscrew ① by turning it counterclockwise with a screwdriver.

- **Attaching the foot holder**

Match the hole in the foot holder ② with the threaded hole in the presser bar ③. Fit the setscrew ① into the hole. Tighten the setscrew ① by turning it clockwise with a screwdriver.

- ① Setscrew
- ② Foot holder
- ③ Presser bar

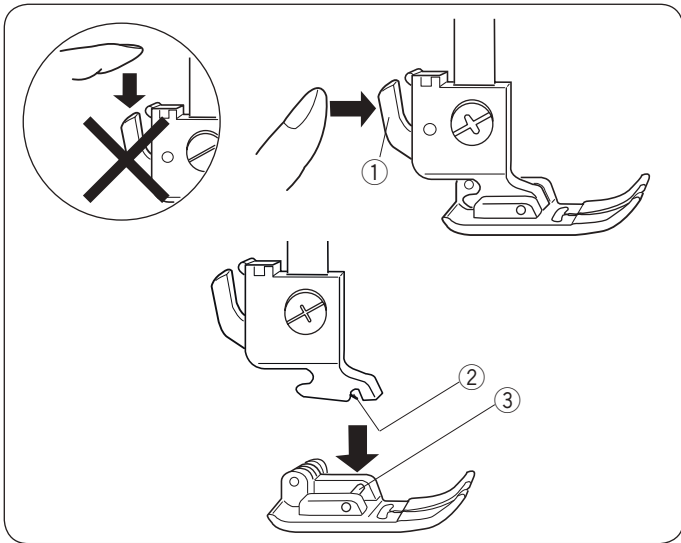

## Changing the Presser Foot

### **⚠ CAUTION:**

Turn OFF the power switch before changing the foot. Always use the proper foot for the selected pattern. The wrong foot can cause the needle to break.

- **Removing the presser foot**

Raise the needle to its highest position by turning the handwheel counterclockwise. Raise the presser foot, and press the lever ① on the back of the foot holder.

- **Attaching the presser foot**

Place the selected presser foot so that the pin ③ on the foot lies just under the groove ② on the foot holder. Lower the presser bar to lock the foot into the place.

- ① Lever
- ② Groove
- ③ Pin

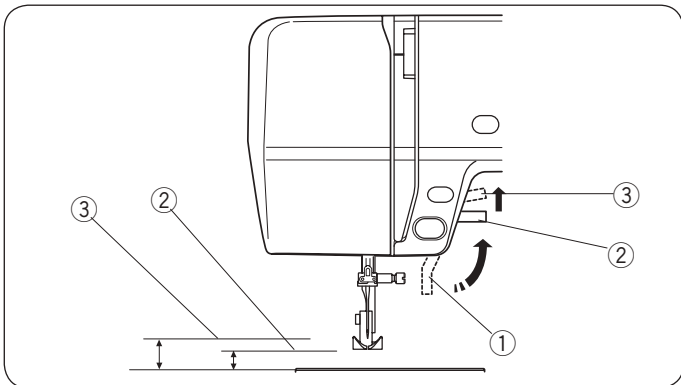

## Presser Foot Lifter

The presser foot lifter ① raises and lowers the presser foot.

You can raise the foot about 1/4" (0.6 cm) higher than the normal up position ② for easy removal of the presser foot, or to help you place thick material under the foot.

- ① Presser foot lifter
- ② Normal up position
- ③ Highest position

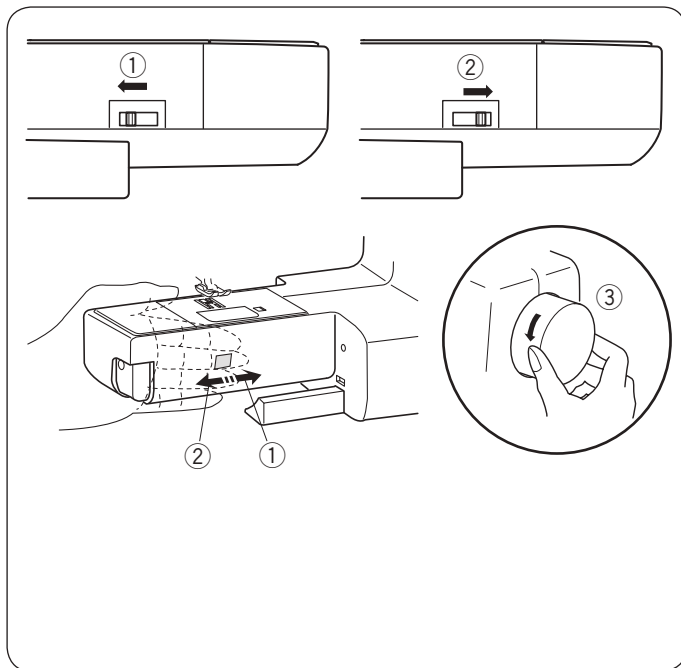

### Dropping or Raising the Feed Dog

The drop feed lever is located underneath the free arm bed on the back of the machine.

- ① To drop the feed dog, push the lever in the direction of the arrow ①.
- ② To raise the feed dog, push the lever in the direction of the arrow ②, as illustrated, and turn the handwheel ③ toward you. The feed dog must be up for normal sewing.

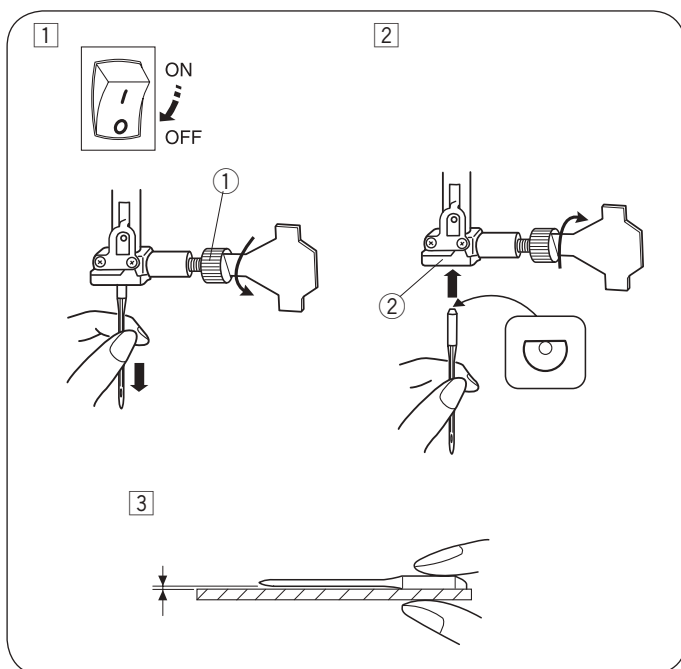

### Changing the Needle

**CAUTION:**  
Turn OFF the power switch before changing the needle.

- ① Turn off the power switch.  
Raise the needle to its highest position by turning the handwheel counterclockwise, and lower the presser foot. Loosen the needle clamp screw ① by turning it counterclockwise. Remove the needle from the needle clamp ②.
- ② Insert a new needle into the needle clamp ② with the flat side to the rear. When inserting the needle into the needle clamp ②, push it up as far as it goes. Tighten the needle clamp screw ① firmly by turning it clockwise.
- ③ To see if the needle is good, place the flat side of the needle onto something flat (needle plate, glass, etc.). The gap between the needle and the flat surface should be consistent. Never use a bent or blunt needle.

A damaged needle can cause permanent snags or runs in knits, fine silks and silk-like fabrics.

- ① Needle clamp screw
- ② Needle clamp

### Selecting Thread and Needles

For general sewing, use needle size 11/75 or 14/90. A fine thread and needle should be used for sewing lightweight fabrics, so the fabric will not be marred. Heavy fabrics require a needle large enough to pierce the fabric without fraying the needle thread. Always test the needle size on a small scrap of the fabric, which will be used for actual sewing. In general, use the same thread for the needle and bobbin. When sewing stretch fabrics, very fine fabrics and synthetics, use a BLUE TIPPED needle. The blue tipped needle effectively prevents skipped stitches.

	Fabric	Thread	Needle
<b>Light</b>	Lawn	Silk #80-100	#9/65–11/75
	Georgette	Cotton #80-100	
	Tricot	Synthetic #80-100	
	Wool, Polyester		
<b>Medium</b>	Cotton, Polyester	Silk #50	#11/75–14/90
	Fine jersey	Cotton #60-80	
	Wool	Synthetic #50-80	#14/90
		Cotton #50	
<b>Heavy</b>	Denim	Silk #50	#14/90–16/100
	Jersey	Cotton #40-50	
	Coating	Synthetic #40-50	#16/100
	Quilting	Silk #30	
		Cotton #50	

## Bobbin Winding

### • Removing the bobbin

Gently slide the hook cover release button ① to the right and remove the hook cover plate ②. Lift out the bobbin.

- ① Hook cover release button
- ② Hook cover plate

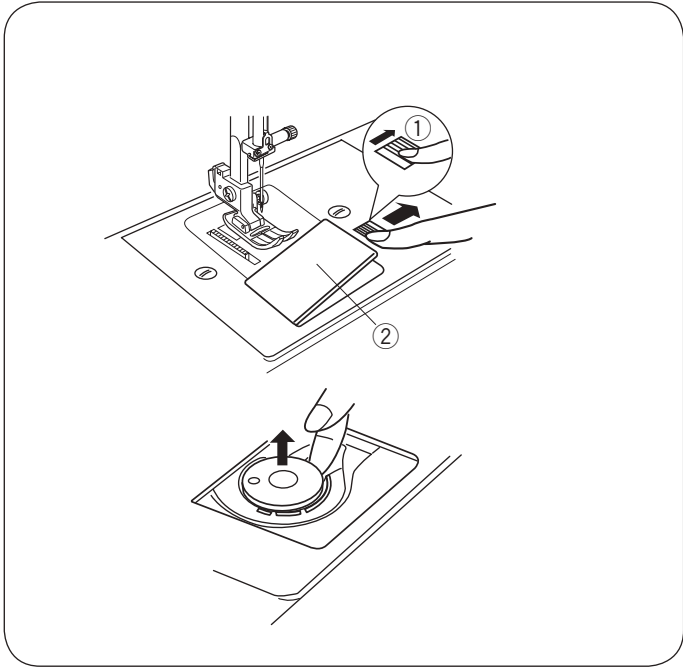

### • Horizontal spool pin

Lift up the spool pin ①. Place a spool of thread on the spool pin with the thread coming off the spool as shown. Attach the large spool holder ②, and press it firmly against the spool of thread.

The small spool holder ③ is used with narrow or small spools of thread.

- ① Spool pin
- ② Large spool holder
- ③ Small spool holder

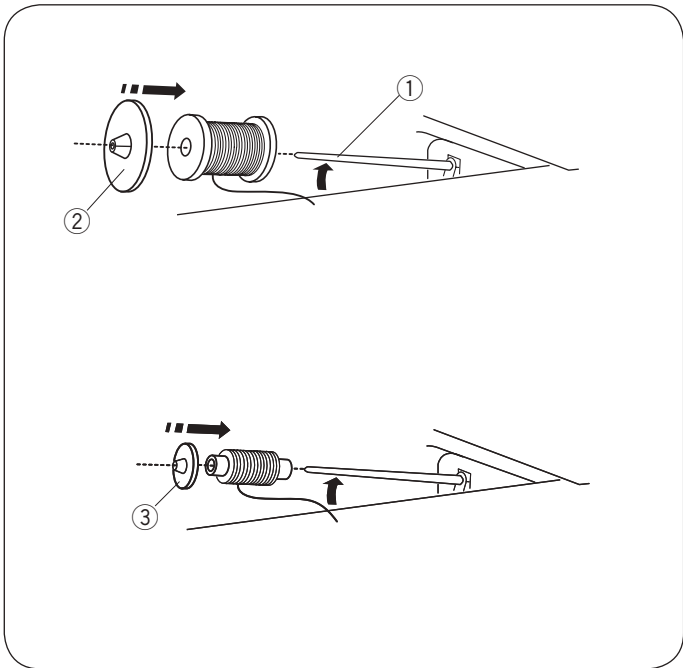

### • Additional spool pin

The additional spool pin ② is for winding bobbins, without unthreading the machine.

Set the spool stand ① under the additional spool pin ②.

Insert the additional spool pin ② into the hole ③.

Place the felt ④ and a spool on the pin.

- ① Spool stand
- ② Additional spool pin
- ③ Hole for additional spool pin
- ④ Spool pin felt

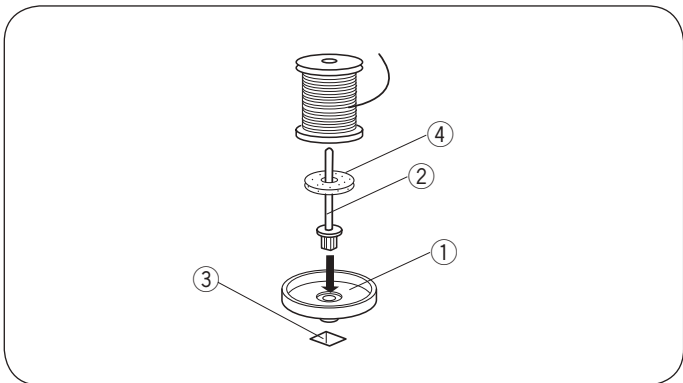

• **Winding the bobbin**

**NOTE:**

Set the speed control slider at its fastest position for bobbin winding.

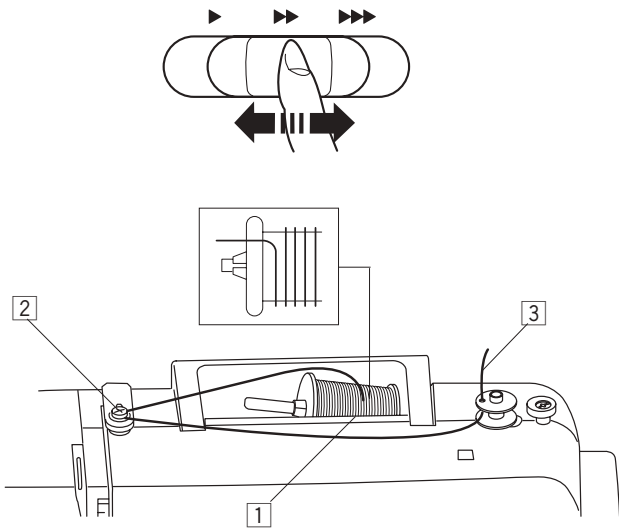

2

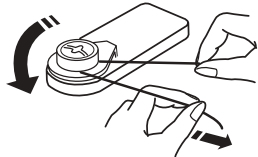

3 4

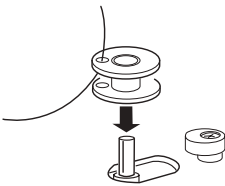

5

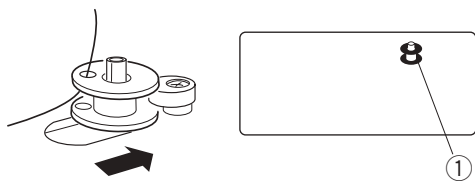

6

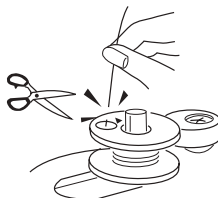

7

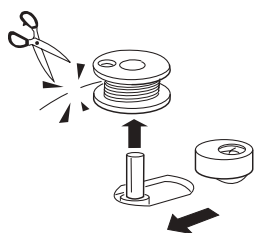

1 Draw the thread from the spool.

2 Guide the thread around the thread guide.

3 Thread through the hole in the bobbin from the inside to the outside.

4 Put the bobbin on the bobbin winder spindle.

5 Push the bobbin to the right.  
The bobbin sign ① appears on the LCD display.

6 With the free end of the thread held in your hand, start the machine. Stop the machine when it has wound a few layers, and then cut the thread close to the hole in the bobbin.

7 Start the machine again. When the bobbin is fully wound, it will stop automatically. Return the bobbin winder to its original position by moving the spindle to the left, and cut the thread as shown.

**NOTE:**

For safety purposes, the machine will stop automatically 2 minutes after the start of bobbin winding.

• **Inserting the bobbin**

1 Place a bobbin in the bobbin holder with the thread running off counterclockwise.

① End of thread

2 Guide the thread into the first notch ② on the front side of the bobbin holder.

② Notch

3 Draw the thread to the left, sliding it between the tension spring blades.

4 Continue to draw the thread lightly until the thread slips into the second notch ③. Pull out about 6" (15 cm) of thread.

③ Notch

5 Attach the hook cover plate. Check the threading by referring to the diagram ④ shown on the hook cover plate.

④ Threading diagram

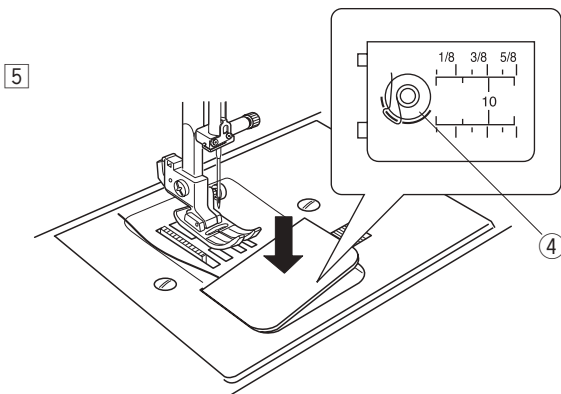
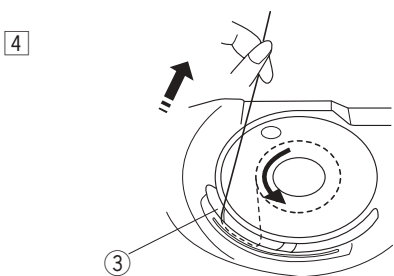
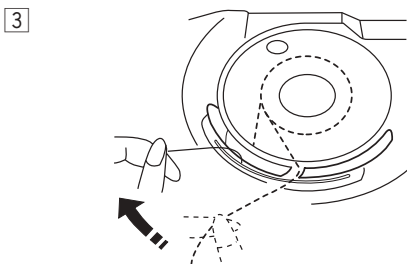
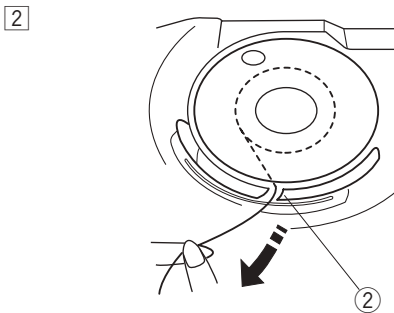
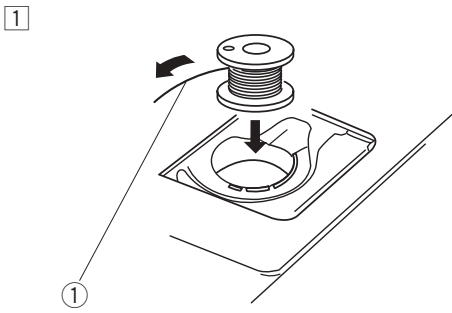

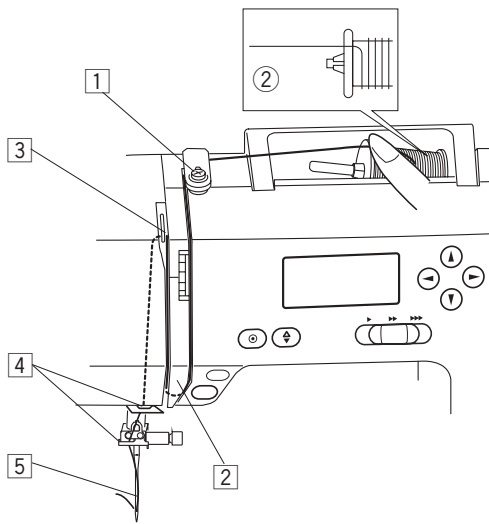

## Threading the Machine

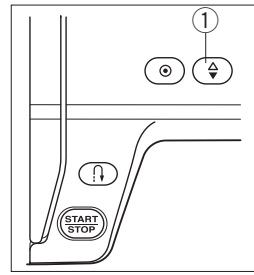

Raise the presser foot. Press the needle up/down button ① to raise the thread take-up lever to its highest position.

① Needle up/down button



### CAUTION:

Turn OFF the power switch before threading the machine.

### • Threading the machine

①

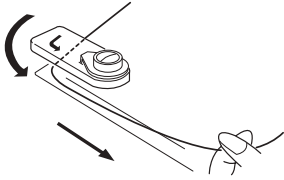

① Draw the end of the thread around the upper thread guide.

②

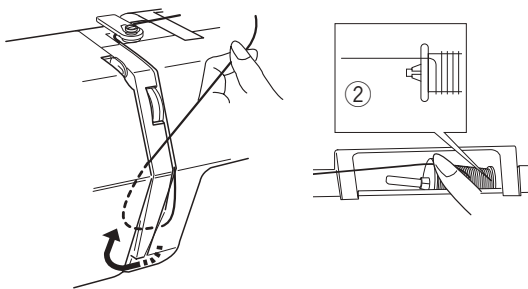

② While holding the thread near the spool ②, draw the end of the thread down around the check spring holder.  
② Spool

③

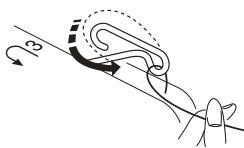

③ Firmly draw the thread up from right to left over the take-up lever, and down into the take-up lever eye.

④ ⑤

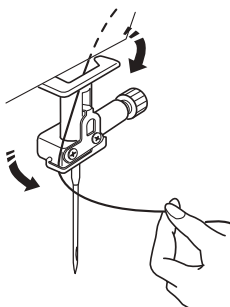

④ Pass the thread through the lower thread guide. Slide the thread behind the needle bar thread guide on the left.

⑤ Thread the needle from front to back, or use the needle threader.

## Needle Threader



### CAUTION:

Turn OFF the power switch when using the needle threader.

1

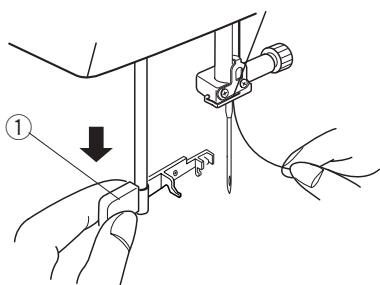

- 1 Lower the presser foot. Raise the needle to its highest position. Pull down the needle threader knob ① as far as it will go.

① Knob

2

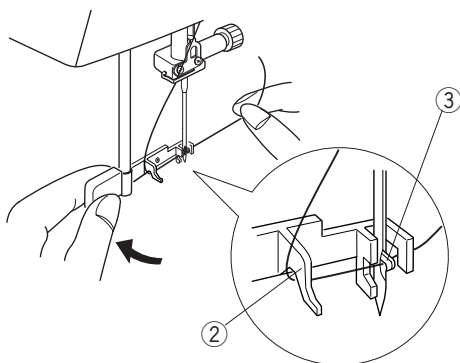

- 2 Turn the knob away from you so the hook comes out through the needle eye.

Draw the thread around the guide ② and under the hook ③.

② Guide

③ Hook

3 4

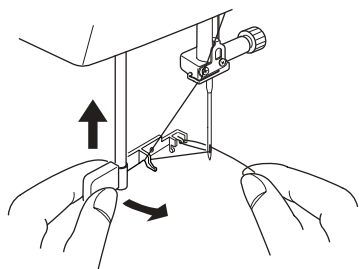

- 3 Turn the knob toward you to pull the thread through the needle eye.

Raise the knob in the direction of the arrow, drawing the thread loop through the needle.

- 4 Pull the thread through the needle eye.

### NOTE:

The needle threader can be used with a #11 to #16 needle or a blue tipped needle. Thread sizes 50 to 90 are recommended.

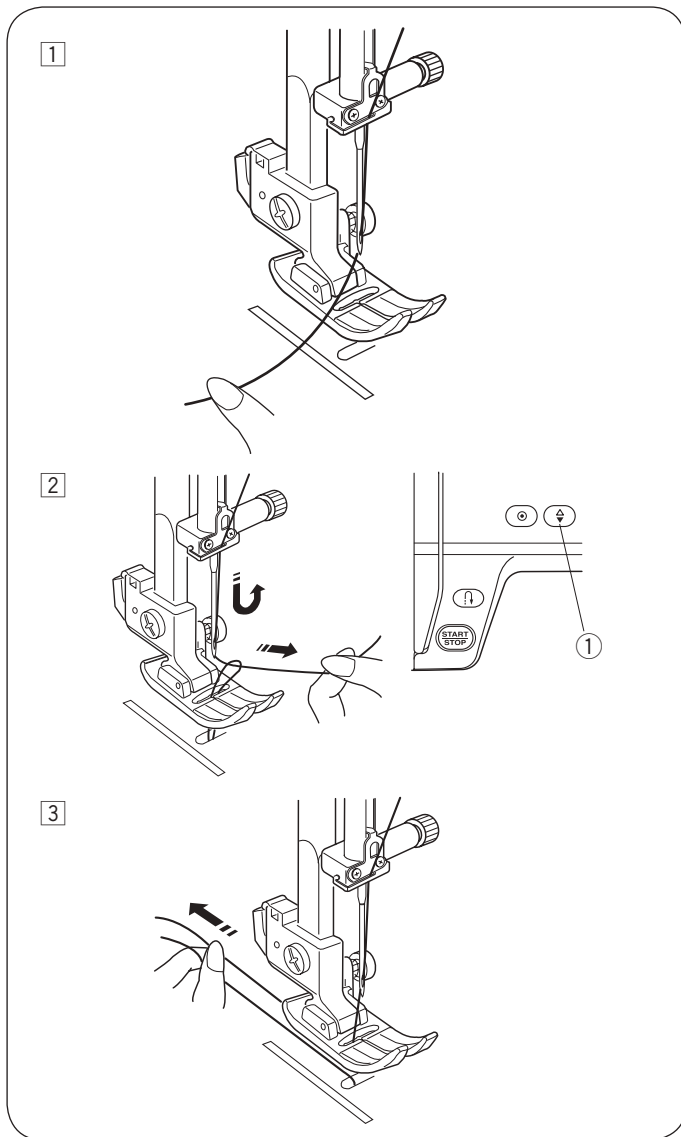

## Drawing up the Bobbin Thread

- 1 Raise the presser foot. Hold the needle thread lightly with your left hand.
- 2 Press the needle up/down button ① twice to lower and raise the needle to pick up the bobbin thread.
  - ① Needle up/down button
- 3 Pull both threads 4" to 6" (10 to 15 cm) under and behind the presser foot.

## LCD Display

The LCD display shows the following information when the machine is turned on.

- ① Stitch pattern number
- ② Cursors
- ③ Stitch width
- ④ Stitch length

- 1 Press the cursor keys (◀▶) to move the cursor under the stitch pattern number. The cursors appear under both digits when turning the power on.
- 2 Press the value set keys (▲▼) to change the stitch pattern number until the pattern number of the desired stitch is indicated. The number will increase or decrease by 1 each time you press the value set key.
- 3 Press the (◀) key to move the cursor under the tens digit of the stitch pattern number. The number will increase or decrease by 10 each time you press the value set key.

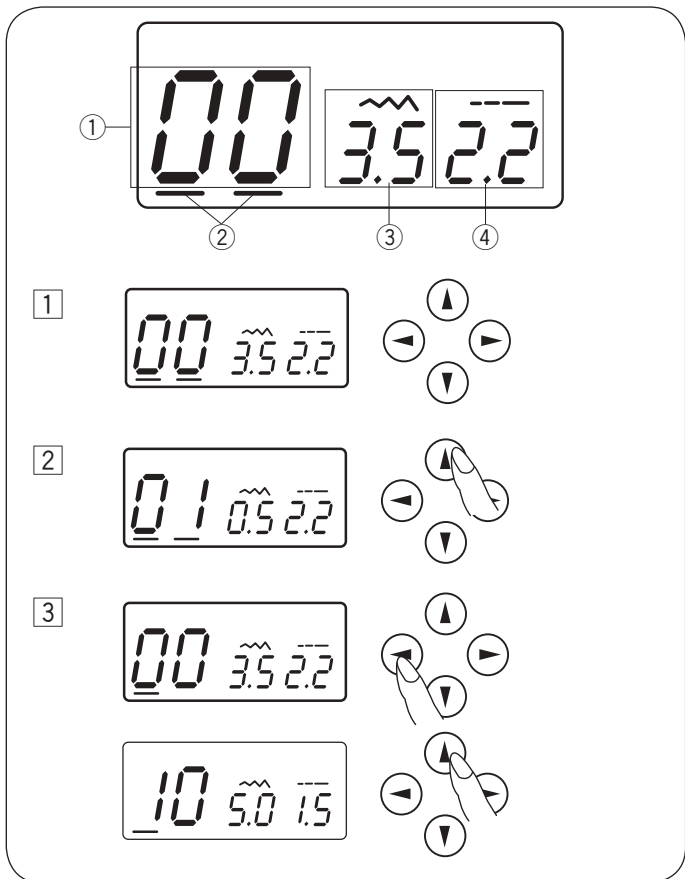

### NOTE:

Shadows of symbols ①, including function icon(s) not available on this model, may be visible on the LCD screen. Refer to the relevant instructions for the applicable symbols to your machine.

## Stitch Patterns

00	01	02	03	04	05	06	07	08	09	10	11	12	13	14	15	16	17	18	19
A					R			F		A					F				
20	21	22	23	24	25	26	27	28	29	30	31	32	33	34	35	36	37	38	39
A		F		A		F		A		F					A		F		
40	41	42	43	44	45	46	47	48	49	50	51	52	53	54	55	56	57	58	59
F		A		F															
60	61	62	63	64	65	66	67	68	69	70	71	72	73	74	75	76	77	78	79
F										F									
80	81	82	83	84	85	86	87	88	89	90	91	92	93	94	95	96	97	98	99
F										F									

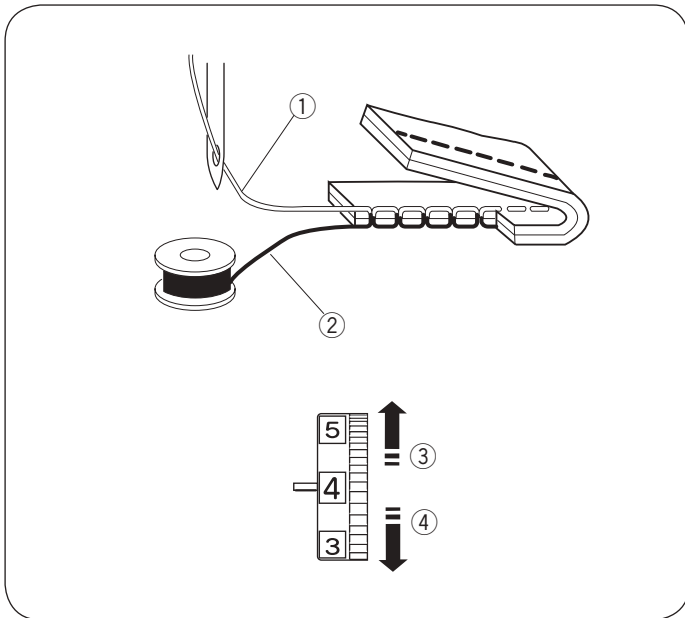

## Adjusting the Needle Thread Tension for a Straight Stitch

### • Correct tension

- ① Needle thread (top thread)
- ② Bobbin thread (bottom thread)
- ③ To loosen
- ④ To tighten

The ideal straight stitch has threads locked between two layers of fabric, as illustrated (magnified to show detail). If you look at the top and bottom of the seam, notice that the stitches are evenly balanced.

When adjusting the needle thread tension, the higher the number, the tighter the top thread tension.

Results depend on:

- stiffness and thickness of the fabric
- number of fabric layers
- type of stitch

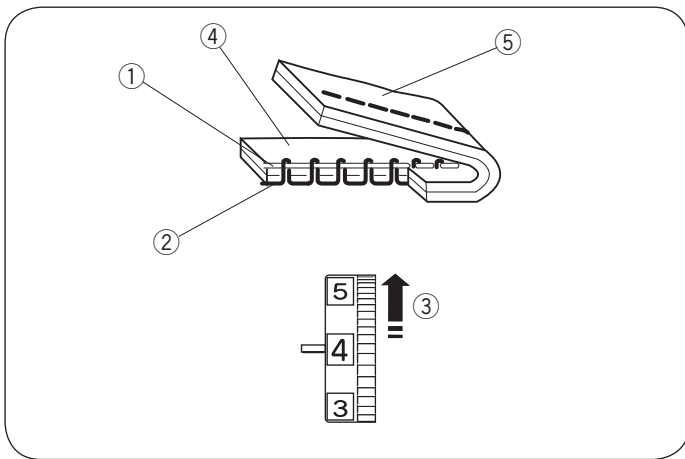

### • Tension is too tight

- ① Needle thread (top thread)
- ② Bobbin thread (bottom thread)
- ③ To loosen tension
- ④ Right side (top side) of fabric
- ⑤ Wrong side (bottom side) of fabric

The bobbin thread shows through on the right side of the fabric, and the stitch feels bumpy. Turn the dial to a lower tension setting number to loosen the needle thread tension.

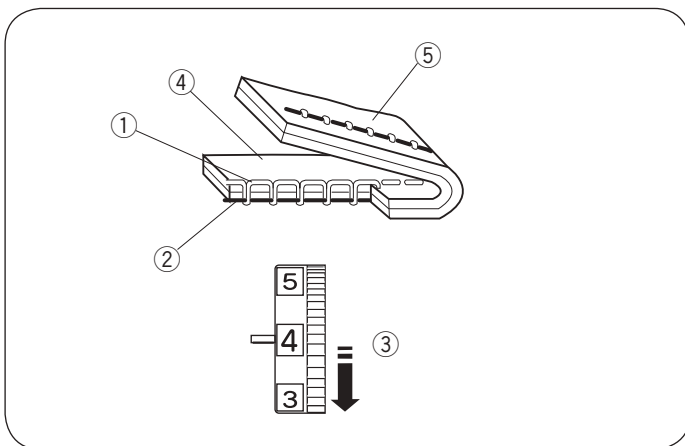

### • Tension is too loose

- ① Needle thread (top thread)
- ② Bobbin thread (bottom thread)
- ③ To tighten tension
- ④ Right side (top side) of fabric
- ⑤ Wrong side (bottom side) of fabric

The needle thread shows through on the wrong side of the fabric, and the stitch feels bumpy. Turn the dial to a higher tension setting number to tighten the needle thread tension.

## Adjusting the Needle Thread Tension for a Zigzag Stitch

For an ideal zigzag stitch, the bobbin thread does not show on the right side (Top side) of the fabric, and the needle thread shows slightly on the wrong side (Bottom side) of the fabric.

See the illustrations for the correct appearance.

To match this appearance, adjust the needle tension as necessary.

### • Correct tension

- ① Right side (Top side) of fabric
- ② Wrong side (Bottom side) of fabric

Minimize the amount of needle thread visible on the wrong side (Bottom side) of the fabric without causing excessive puckering, or causing the bobbin thread to show on the right side (Top side) of the fabric. Results vary with fabric, thread and sewing conditions.

### • Tension is too tight

- ① Right side (Top side) of fabric
- ② Wrong side (Bottom side) of fabric

The corner of each zigzag pulls together on the right side of the fabric.

### • Tension is too loose

- ① Right side (Top side) of fabric
- ② Wrong side (Bottom side) of fabric

The corner of each zigzag point pulls together on the wrong side of the fabric.

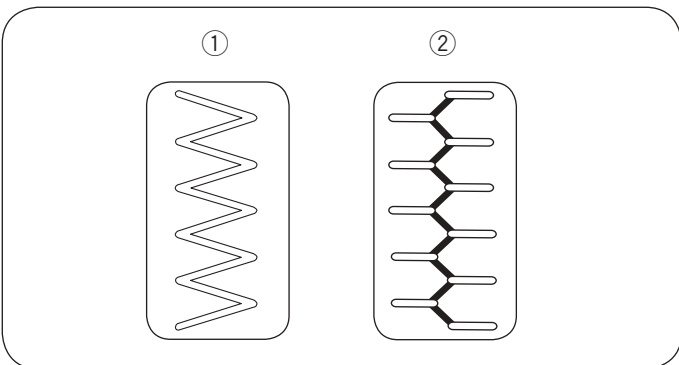
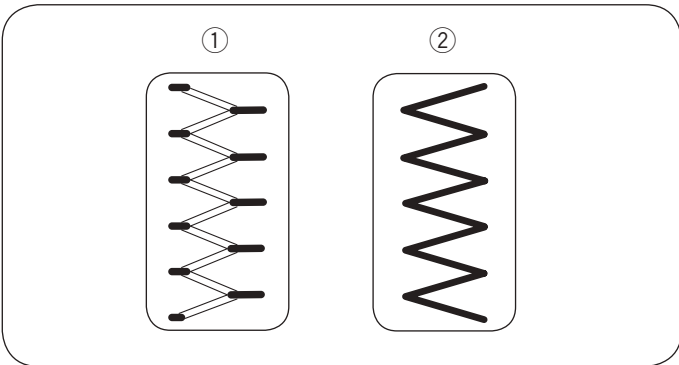
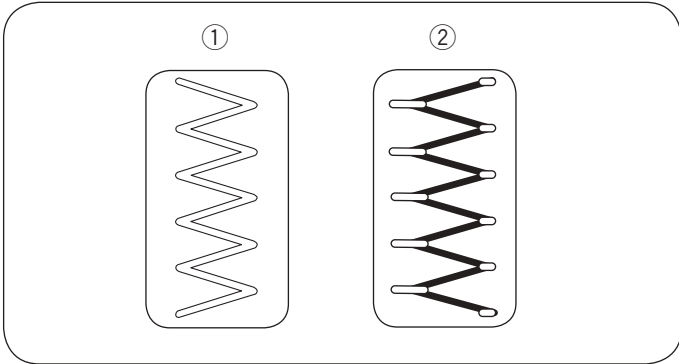

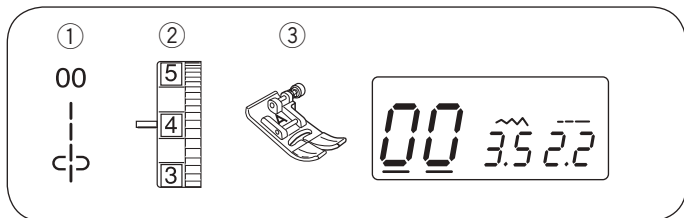

## SECTION III. BASIC SEWING

### Straight Stitch Sewing

- ① Stitch pattern: 00 or 01
- ② Needle thread tension: 2 to 6
- ③ Presser foot: Zigzag foot A

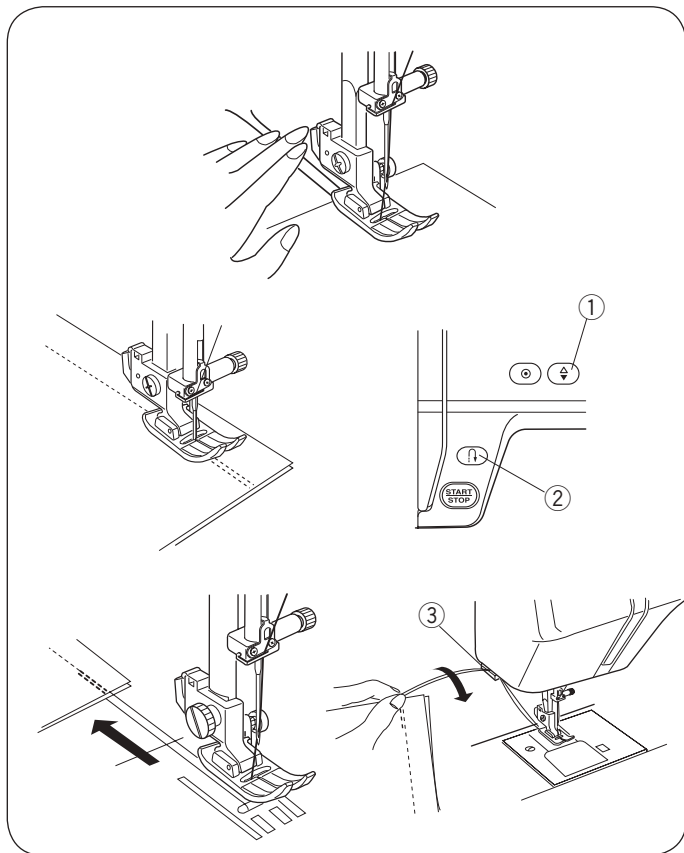

#### • Starting to sew

Raise presser foot and position the fabric next to a seam guide line on the needle plate (5/8" (1.6 cm) is most common). Lower the needle to the point where you want to start. Lower the presser foot and pull the threads toward the back. Start the machine. Gently guide the fabric along a seam guide line letting the fabric feed naturally.

#### • Changing sewing direction

Stop the machine and bring the needle down into the fabric by pressing the needle up/down button ①.

Raise the presser foot.

Pivot the fabric around the needle to change the sewing direction as desired. Lower the presser foot.

- ① Needle up/down button

#### • Finishing sewing

To fasten the ends of a seam, press the reverse stitch button ② and sew several reverse stitches. Raise the presser foot. Remove the fabric, draw the threads to the back and cut them with the thread cutter ③. The threads are cut a proper length to begin sewing the next seam.

- ② Reverse stitch button
- ③ Thread cutter

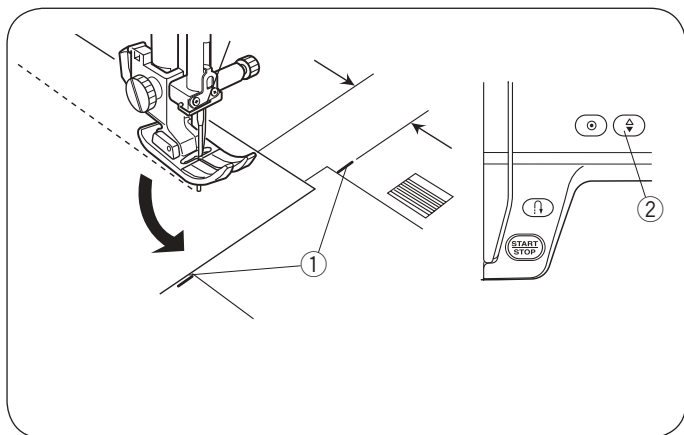

#### • Turning square corners

When sewing with fabric edge at 5/8" seam guide, to turn a square corner so that sewing continues at same distance from edge.

Stop the machine when front edge of fabric reaches the cornering guide lines ①.

Lower the needle by pressing needle up/down button ②. Raise the presser foot and turn the fabric counterclockwise 90°.

Lower the presser foot, and begin stitching in the new direction.

- ① Cornering guide
- ② Needle up/down button

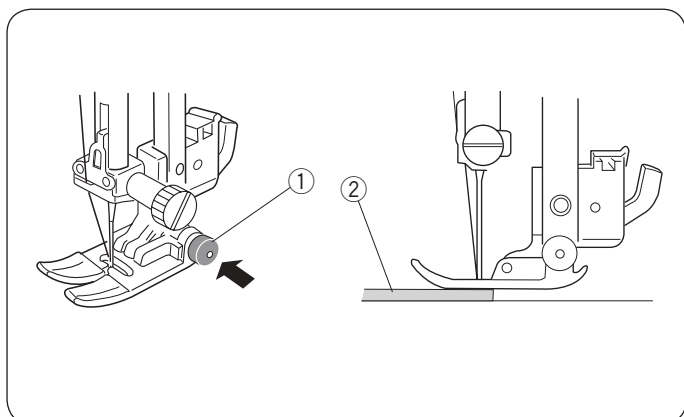

#### • Sewing from the edge of thick fabric

The black button ① on the zigzag foot locks the foot in the horizontal position.

This is helpful when starting sewing from the far edge of thick fabrics ② or sewing across a hem.

Lower the needle into the fabric at the point where you wish to start sewing.

Lower the foot while pushing the black button ① in. The foot is locked in the horizontal position to avoid slipping. The button is released automatically after sewing a few stitches.

- ① Black button
- ② Thick fabrics

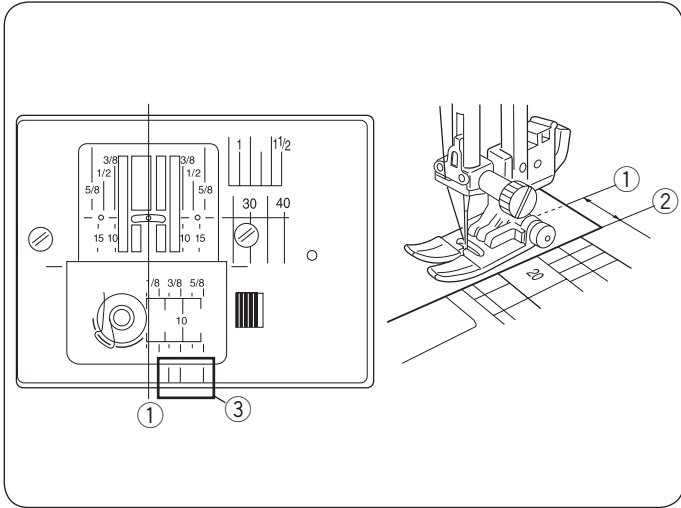

### Needle Plate

The seam guides on the needle plate and the hook cover help you to measure seam allowance. The numbers on the needle plate indicate the distance between the center needle position ① and the edge of the fabric ②.

- ① Center needle position
- ② Edge of the fabric

Number	10	15	30	40	3/8	1/2	5/8	1	1 1/2
Distance (cm)	1.0	1.5	3.0	4.0	—	—	—	—	—
Distance (inch)	—	—	—	—	3/8	1/2	5/8	1	1 1/2

The front seam guides ③ are marked at 1/4", 3/8" and 5/8" from the center needle position ①.

- ③ Front seam guides

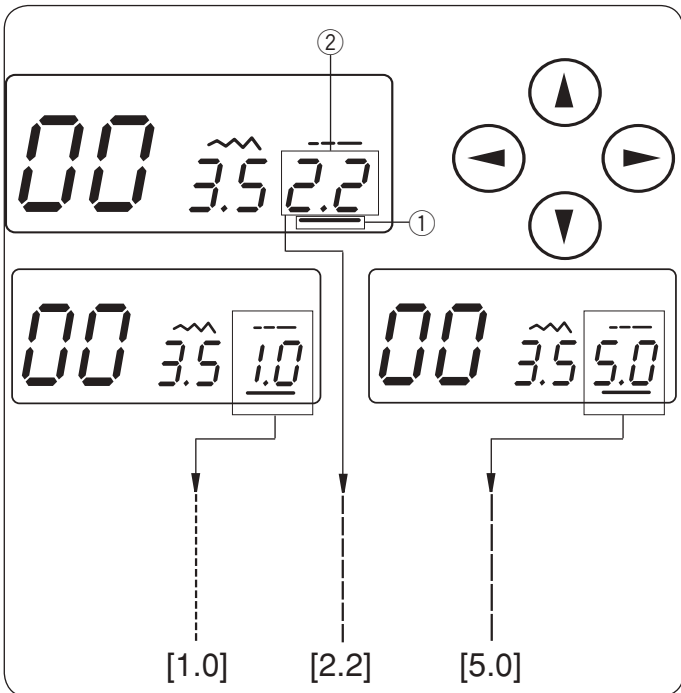

### • Adjusting the stitch length

Press the cursor buttons (◀ ▶) to move the cursor ① under the stitch length value "2.2" ② (default setting).

Press the (▼) button to decrease stitch length.

Press the (▲) button to increase stitch length.

The stitch length can be varied from 0.0 to 5.0.

- ① Cursor
- ② Stitch length (2.2)

#### NOTE:

Reverse stitch length cannot be set longer than 4.0.

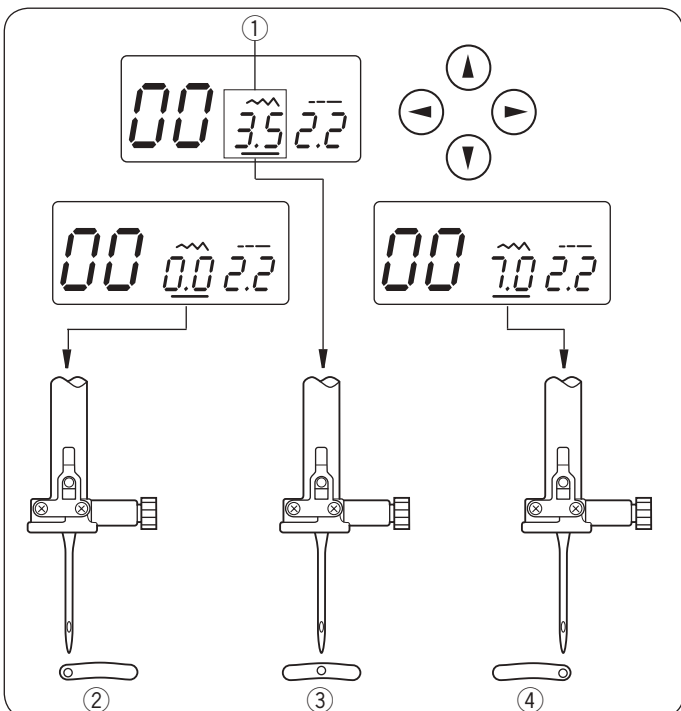

### • Adjusting the needle drop position

The needle drop position can be adjusted for straight stitch patterns 00–03, and 21–23.

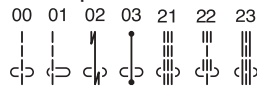

Press the cursor buttons (◀ ▶) to move the cursor ① under the stitch width value "3.5" (default setting).

Press the (▲) button to move the needle to the right ④.

Press the (▼) button to move the needle to the left ②.

- ② Left (0.0)
- ③ Middle (3.5)
- ④ Right (7.0)

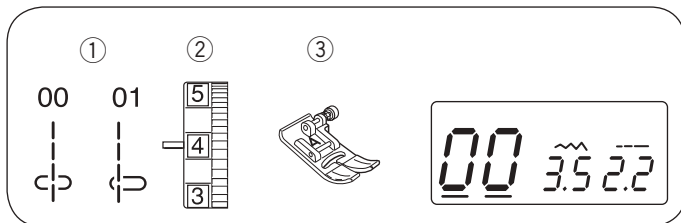

### Straight Stitch

- ① Stitch pattern: 00 or 01
- ② Needle thread tension: 2 to 6
- ③ Presser foot: Zigzag foot A

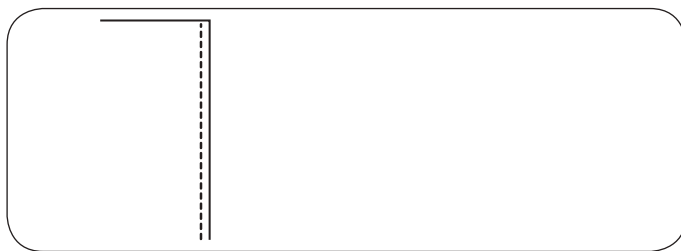

For seaming garments, zipper application and more. Pattern 01 is used for seaming fine fabrics.

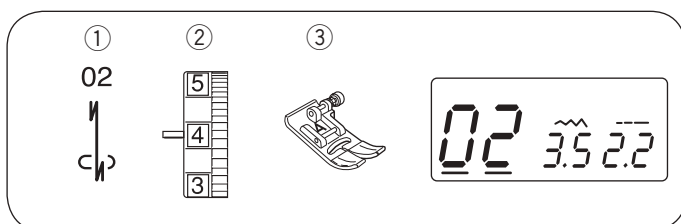

### Lock-a-Matic Stitch

- ① Stitch pattern: 02
- ② Needle thread tension: 2 to 6
- ③ Presser foot: Zigzag foot A
- ④ Reverse button

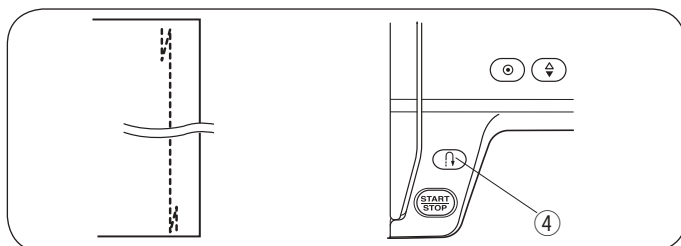

Use this stitch to secure the beginning and the end of a seam with backstitching. When you reach the end of the seam, press the reverse stitch button ④ once. The machine will sew four reverse stitches, four forward stitches, and then stop sewing automatically.

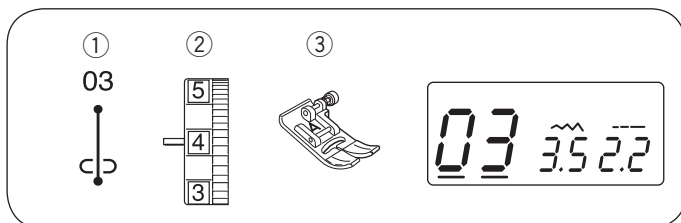

### Locking Stitch

- ① Stitch pattern: 03
- ② Needle thread tension: 2 to 6
- ③ Presser foot: Zigzag foot A
- ④ Reverse button

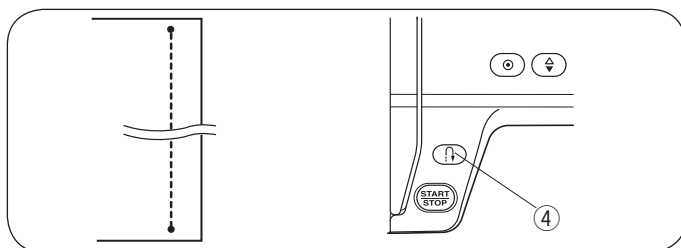

This unique stitch is used where an invisible locking stitch is needed. Lower the needle close to the front edge of the fabric. The machine will sew several locking stitches in place and continue sewing forward. When you press the reverse stitch button ④ at the end of the seam, the machine will sew several locking stitches in place, then stop sewing automatically.

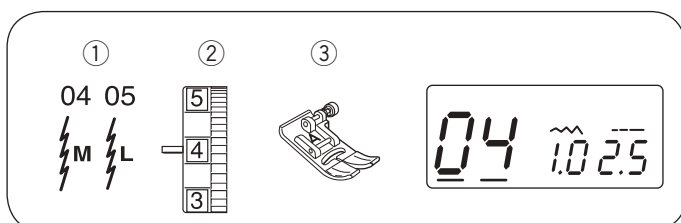

### Stretch Stitch

- ① Stitch pattern: 04 or 05
- ② Needle thread tension: 3 to 6
- ③ Presser foot: Zigzag foot A



This stitch is a narrow stretch stitch designed to eliminate puckering on knit fabrics and bias seams, while permitting the seam to be pressed completely open flat.

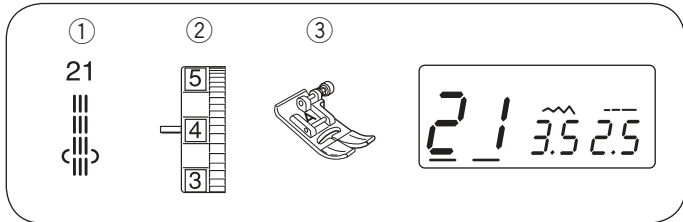

### Triple Stretch Stitch

- ① Stitch pattern: 21
- ② Needle thread tension: 2 to 6
- ③ Presser foot: Zigzag foot A

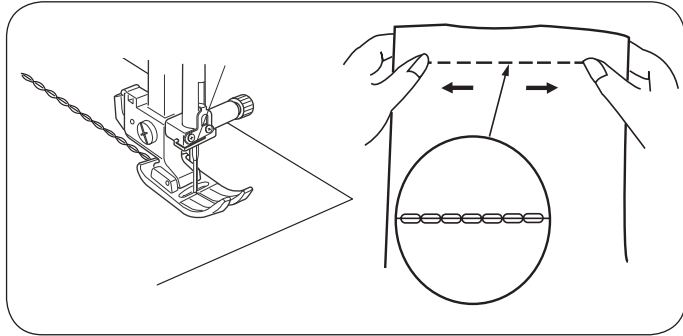

This strong, durable stitch is recommended when both elasticity and strength are necessary in order to insure comfort and durability. Use it to reinforce areas such as crotch and armhole seams. Also use for extra reinforcement when constructing items such as backpacks.

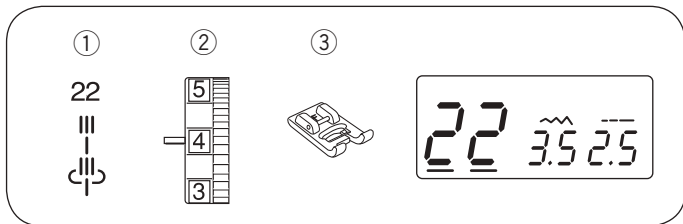

### Sculpture Stitch

- ① Stitch pattern: 22
- ② Needle thread tension: 3 to 6
- ③ Presser foot: Satin stitch F

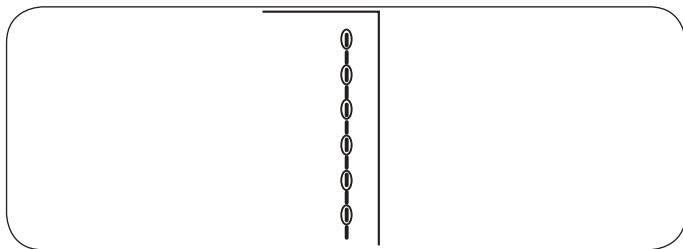

For top stitching and outlining designs. Sew slowly at the corners.

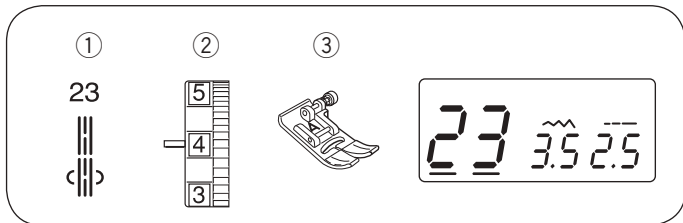

### Saddle Stitch

- ① Stitch pattern: 23
- ② Needle thread tension: 3 to 6
- ③ Presser foot: Zigzag foot A

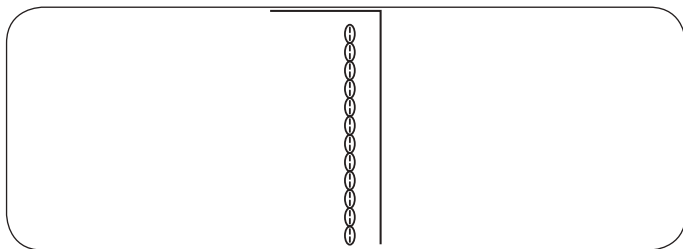

This saddle stitch is formed with one stitch forward, two stitches backward, and a fourth stitch forward. You can achieve a lovely hand-worked look when topstitching suits, blazers, jumpers, and denim outfits with the saddle stitch.

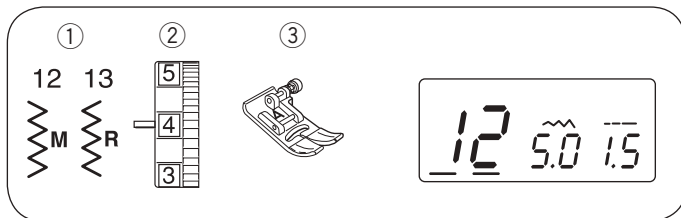

### Zigzag Stitch

- ① Stitch pattern: 12 or 13
- ② Needle thread tension: 2 to 6
- ③ Presser foot: Zigzag foot A

The zigzag stitch is one of the most useful and versatile stitches.

It is used for overcasting, mending, appliqué, and also used as a decorative stitch.

#### NOTE:

Use an interfacing when sewing on stretch fabrics such as knit, jersey or tricot.

#### • Adjusting the stitch width

Press the cursor buttons ◀ ▶ to move the cursor ② under the stitch width value "5.0" ① (default setting).

Press the ▼ button to decrease stitch width ③.

Press the ▲ button to increase stitch width ④.

The stitch width can be varied from 0.0 to 7.0.

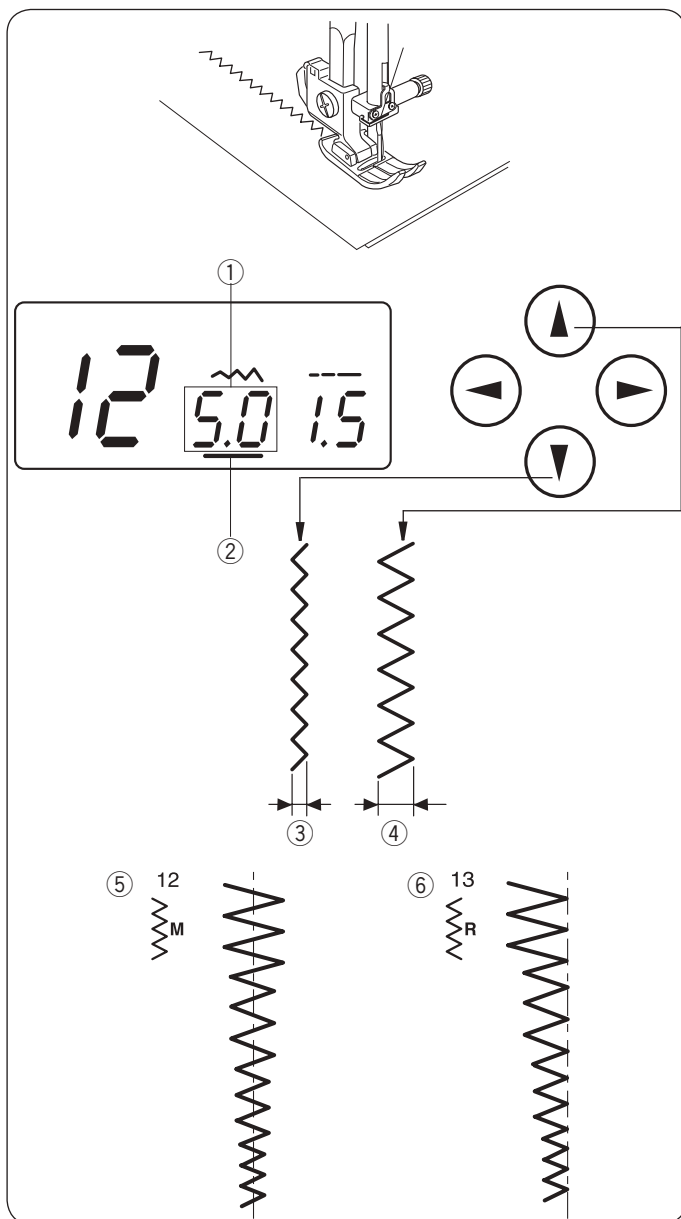

⑤ The stitch width of pattern 12 can be changed without changing its center needle position (M).

⑥ The stitch width of pattern 13 can be changed without changing its right needle position (R).

#### • Adjusting the stitch length

Press the cursor buttons ◀ ▶ to move the cursor ② under the stitch length value "1.5" ⑤ (default setting).

Press the ▼ button to decrease stitch length ⑥.

Press the ▲ button to increase stitch length ⑦.

The stitch length can be varied from 0.2 to 5.0.

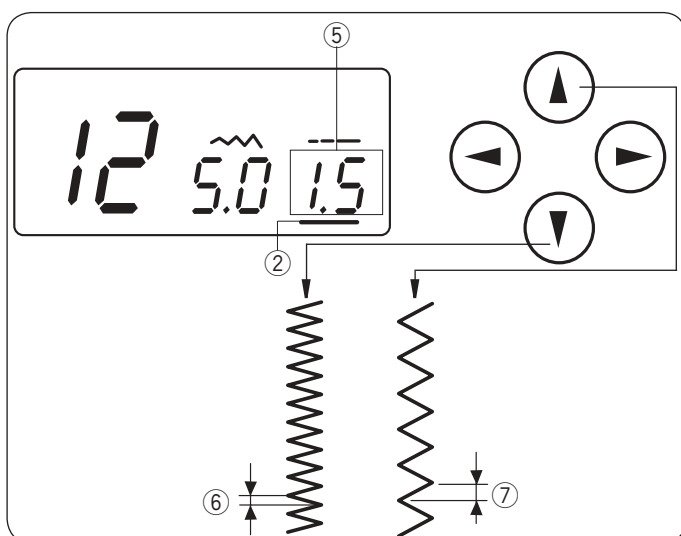

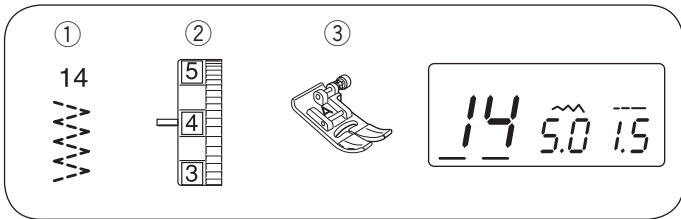

### Multiple Zigzag

- ① Stitch pattern: 14
- ② Needle thread tension: 3 to 6
- ③ Presser foot: Zigzag foot A

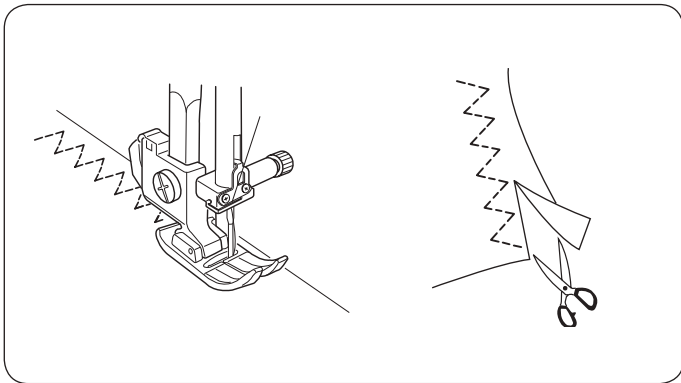

This stitch is used to finish seams on synthetics and other fabrics that tend to pucker. The stitch is also excellent for darning and mending tears.

Place your fabric to allow a 5/8" (1.5 cm) seam. Trim excess close to stitching. Be careful not to cut the stitches.

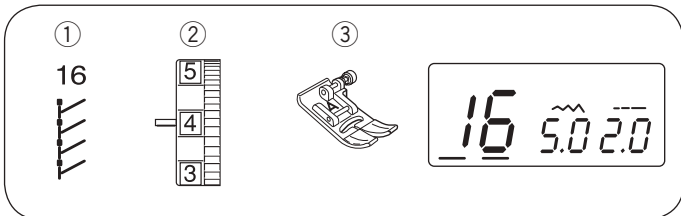

### Knit Stitch

- ① Stitch pattern: 16
- ② Needle thread tension: 3 to 6
- ③ Presser foot: Zigzag foot A

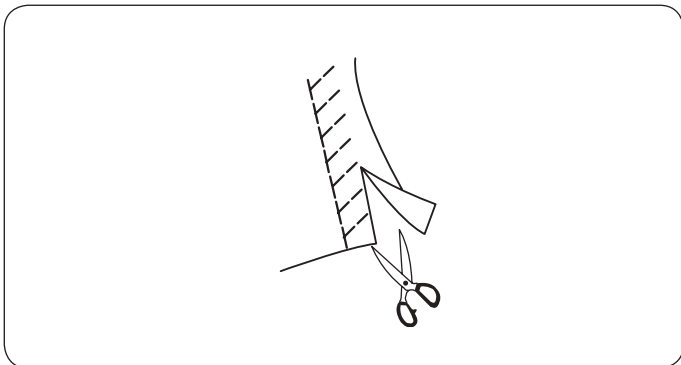

Place your fabric to allow a 5/8" (1.5 cm) seam. Trim excess close to stitching. Be careful not to cut the stitches.

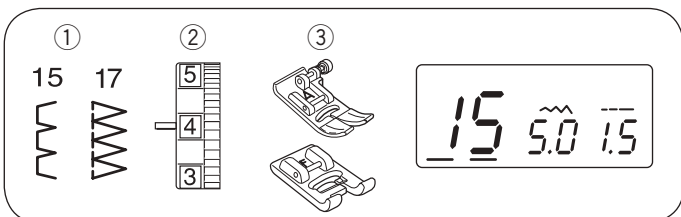

### Overedge Stitch

- ① Stitch pattern: 15 or 17
- ② Needle thread tension: 3 to 6
- ③ Presser foot: Zigzag foot: A  
Satin Stitch foot: F

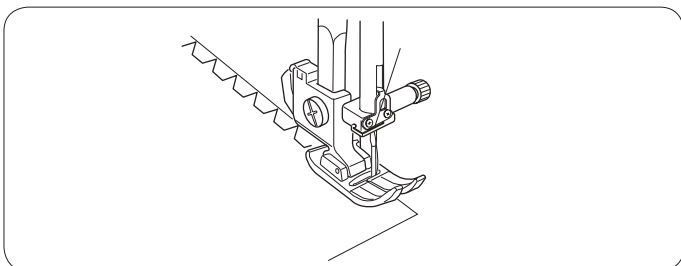

Carefully guide the fabric so the needle falls off the edge when it swings to the right.

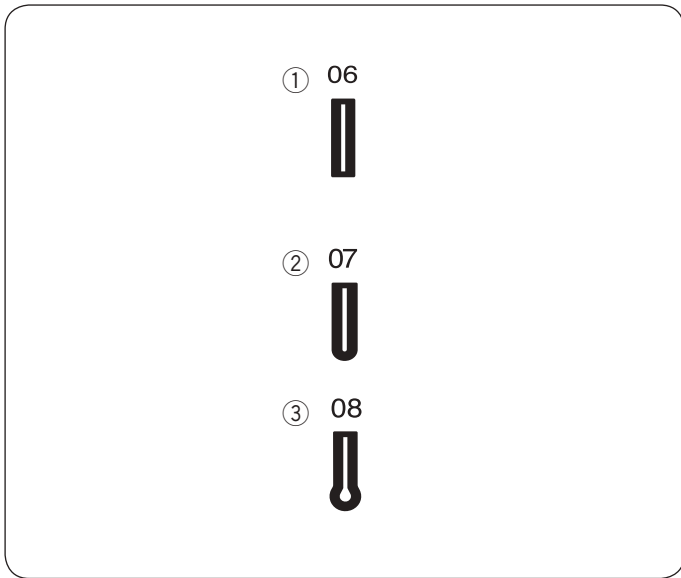

## Various Kinds of Buttonholes and Their Uses

### ① Square Buttonhole

This square buttonhole is widely used on medium to heavy fabrics. The buttonhole size is automatically determined by placing a button in the foot.

### ② Round-end Buttonhole

This buttonhole is used on fine to medium weight fabrics, especially for blouses and children's clothes.

### ③ Keyhole Buttonhole

The keyhole buttonhole is widely used on medium to heavy fabrics. It is also suitable for larger and thicker buttons.

#### NOTES:

- To sew the buttonholes 06 to 08, follow the same procedure as Square BH (See page 26 to 27.).
- The size of a buttonhole is automatically set by placing a button in the rear of automatic buttonhole foot R.
- The button holder of the foot takes a button size of up to 1" (2.5 cm) in diameter.
- It is sometimes necessary to change buttonhole size to match certain heavy or specific materials and threads.
- Make a test buttonhole on an extra piece of the fabric to check your setting.
- Place the button on the fabric and mark the top and bottom to determine the position of the buttonhole on the fabric.
- Use interfacing on stretch fabrics.

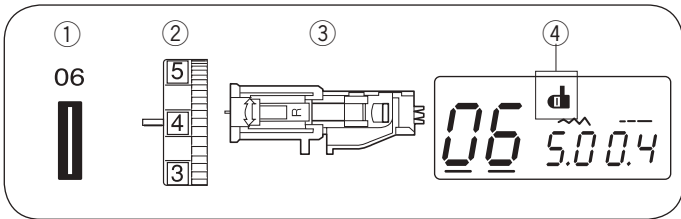

## Square Buttonhole

- ① Stitch pattern: 06
- ② Thread tension dial: 1 to 5
- ③ Presser foot: Automatic buttonhole foot R
- ④ Buttonhole lever sign

### • To sew

- ① Press the needle up/down button to raise the needle. Attach the automatic buttonhole foot R snapping the pin ② into the groove ① of the foot holder.

- ① Groove
- ② Pin

- ② Pull the button holder ③ to the back, and place the button in it. Push it together tightly to the button.

### NOTE:

If the button is extremely thick, make a test buttonhole on an extra piece of the fabric. If it is difficult to fit the button through the test buttonhole, you can lengthen the buttonhole by pulling the button holder back a little. The length of the buttonhole will be increased.

- ③ Button holder
- ④ Extra gap

- ③ Pull the buttonhole lever ⑤ down as far as it will go.
- ⑤ Buttonhole Lever

- ④ Insert the corner of the fabric under the foot. Press the needle up/down button twice. Remove the fabric to the left to draw the needle thread through the hole of the foot. Place the fabric under the foot, and lower the needle at the starting point of the buttonhole mark ⑥. Then lower the automatic buttonhole foot R.

- ⑥ Buttonhole mark
- ⑦ Starting point

### NOTE:

Make sure there is no gap ⑩ between the slider and stopper, otherwise the buttonhole will not be sewn in the required position.

- ⑧ Slider
- ⑨ Stopper
- ⑩ No gap
- ⑪ Sewing gap

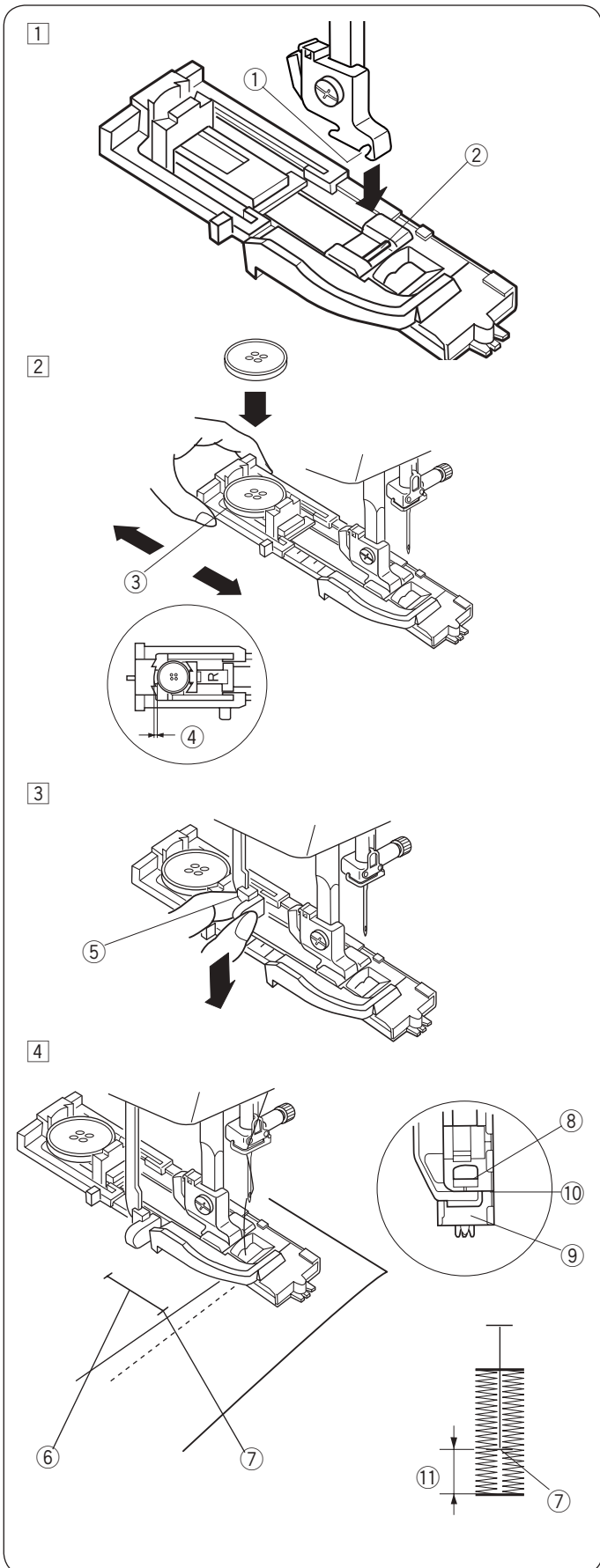

5

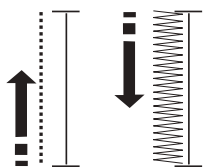

6

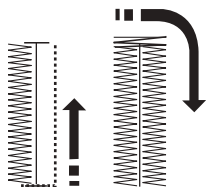

7

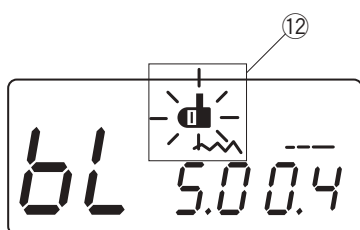
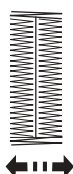

8

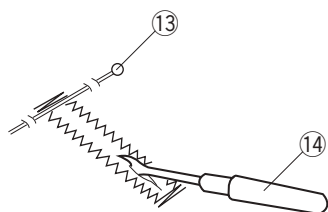

9

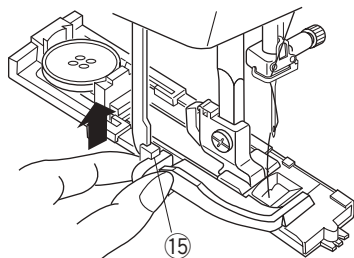

5 Start the machine to sew the buttonhole.  
The buttonhole will be automatically sewn.  
The machine will sew the left row first.

6 The machine will sew the back bartack and the right row.

7 The machine will sew the front bartack, then it stops automatically.

**NOTE:**

If you start sewing the buttonhole without lowering the buttonhole lever, the LCD display will show “bL” message and the buttonhole lever sign ⑫ will blink. Lower the buttonhole lever, then restart the machine.

8 Remove the fabric and place a pin ⑬ just below the bartack at each end to prevent accidentally cutting stitches. Cut the opening with the seam ripper ⑭.

⑬ Pin

⑭ Seam ripper

9 When buttonhole sewing is finished, push the buttonhole lever ⑮ upward as far as it will go.

⑮ Buttonhole lever

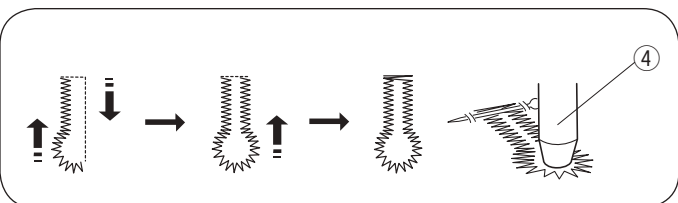
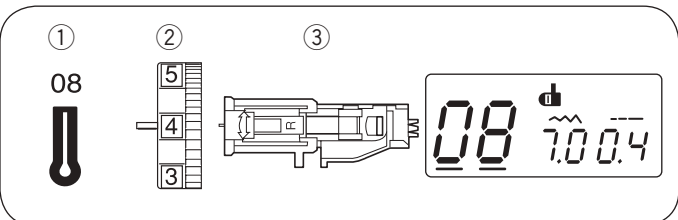
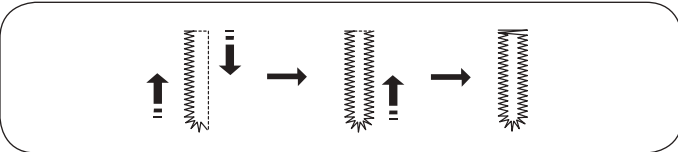
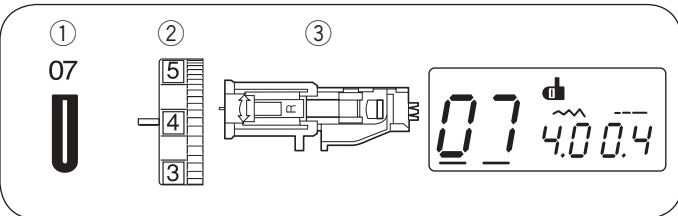
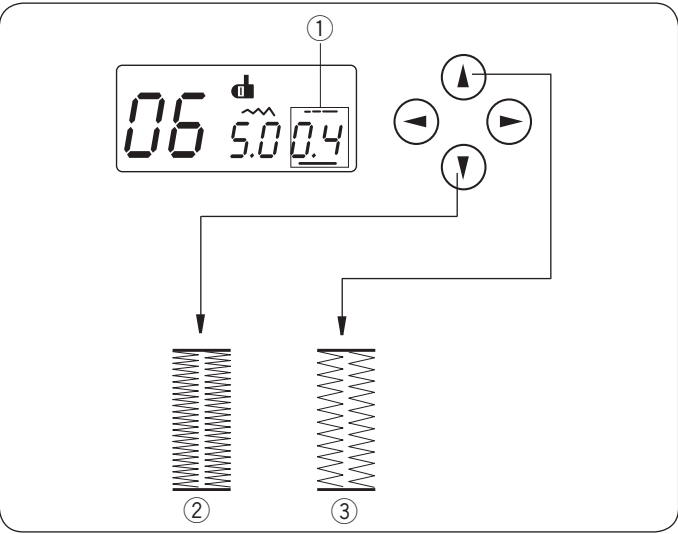
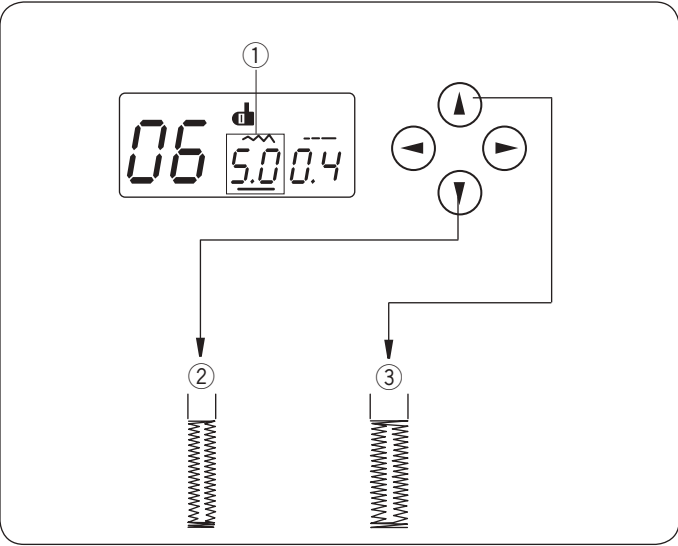

## Adjusting the Stitch Width and Density for Buttonholes

### • Adjusting the stitch width

Press the cursor buttons (◀ ▶) to move the cursor under the stitch width value “5.0” ① (default setting). Press the (▼) button to decrease buttonhole width ②. Press the (▲) button to increase buttonhole width ③. The stitch width can be varied from 2.5 to 7.0 depending on the selected buttonhole.

### • Adjusting the stitch density

Press the cursor buttons (◀ ▶) to move the cursor under the stitch density value “0.4” ① (default setting). Press the (▼) button to make the buttonhole stitch denser ②. Press the (▲) button to make the buttonhole stitch less dense ③. The stitch density can be varied from 0.3 to 0.8 depending on the selected buttonhole.

## Round-End Buttonhole

- ① Stitch pattern: 07
- ② Thread tension dial: 1 to 4
- ③ Presser foot: Automatic buttonhole foot R

Sewing procedure is the same as square buttonhole. The stitch width can be varied from 2.5 to 5.5. To change the stitch width or stitch density, refer to the “Adjusting the stitch density” section above.

## Keyhole Buttonhole

- ① Stitch pattern: 08
- ② Thread tension dial: 1 to 5
- ③ Presser foot: Automatic buttonhole foot R
- ④ Eyelet punch

Sewing procedure is the same as square buttonhole. Use the seam ripper and an eyelet punch ④ to open the buttonhole.

The stitch width can be varied from 5.5 to 7.0. To change the stitch width or density, “Adjusting the stitch density” section above.

\* An eyelet punch is an optional item.

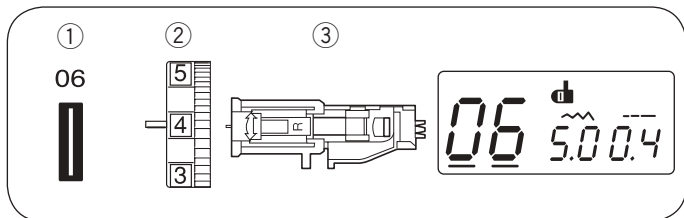

### Corded Buttonhole

- ① Stitch pattern: 06
- ② Thread tension dial: 1 to 5
- ③ Presser foot: Automatic buttonhole foot R

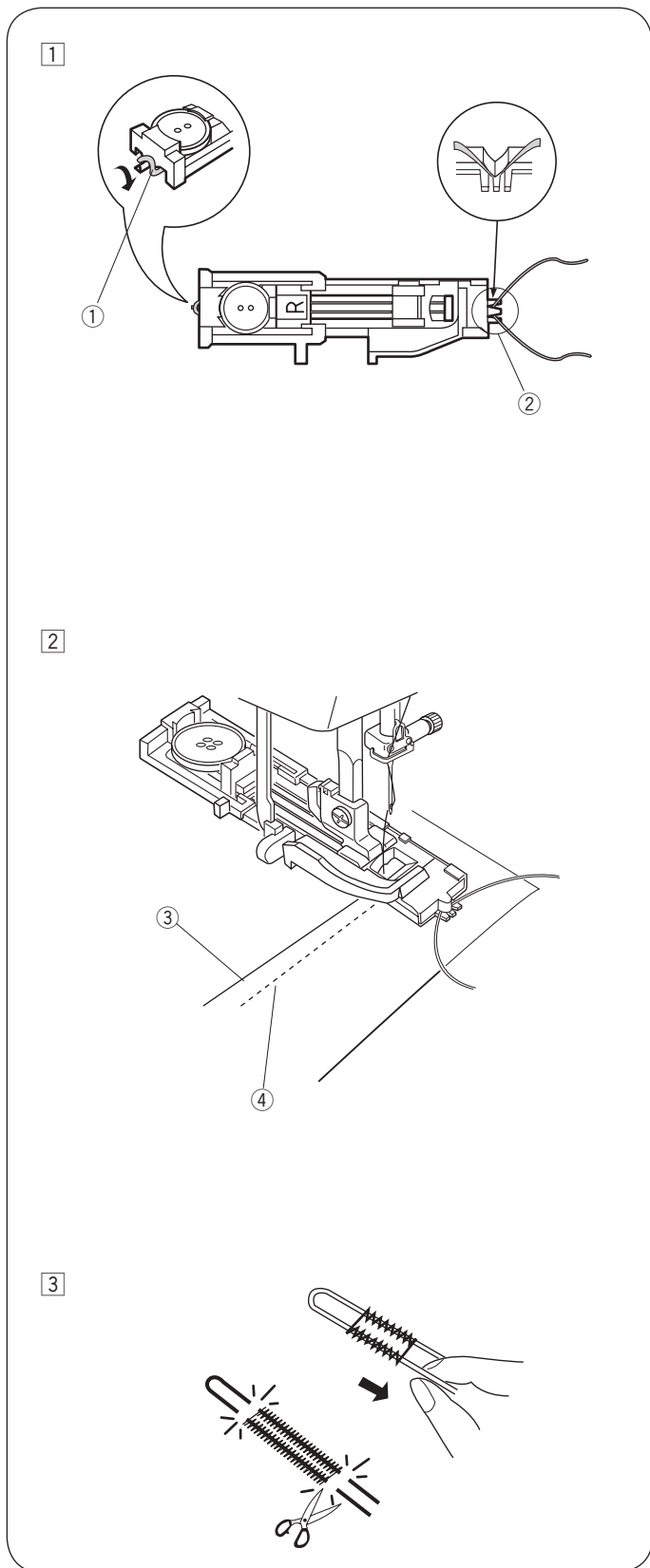

- ① Use the same procedure as the square buttonhole procedure. Set the stitch width to match the thickness of the cord used. With the buttonhole foot raised, hook the filler cord on the spur ① at the back of the buttonhole foot. Bring the ends toward you under the buttonhole foot, clearing the front end. Hook the filler cord into the forks ② on the front of the automatic buttonhole foot to hold them tight. Lower the needle into the garment where the buttonhole will start, and lower the foot.
  - ① Spur
  - ② Forks

- ② Start the machine and sew the buttonhole. Each side of the buttonhole and the bartacks will be sewn over the cord. Remove the fabric from the machine, and cut the sewing threads only.
  - ③ Needle thread (top thread)
  - ④ Bobbin thread (bottom thread)

- ③ Pull the loose ends of the filler cord to tighten it. Thread the end of the cord through a hand-sewing needle. Then draw them to the wrong side of the fabric and knot.

**NOTE:**  
Cut the filler cord at both ends, if the filler cord is stitched on the fabric and cannot be pulled.

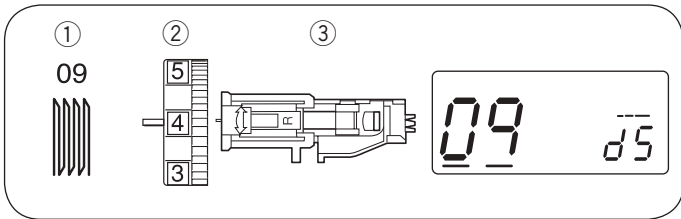

## Darning Stitch

- |                        |                             |
|------------------------|-----------------------------|
| ① Stitch pattern:      | 09                          |
| ② Thread tension dial: | 3 to 6                      |
| ③ Presser foot:        | Automatic buttonhole foot R |

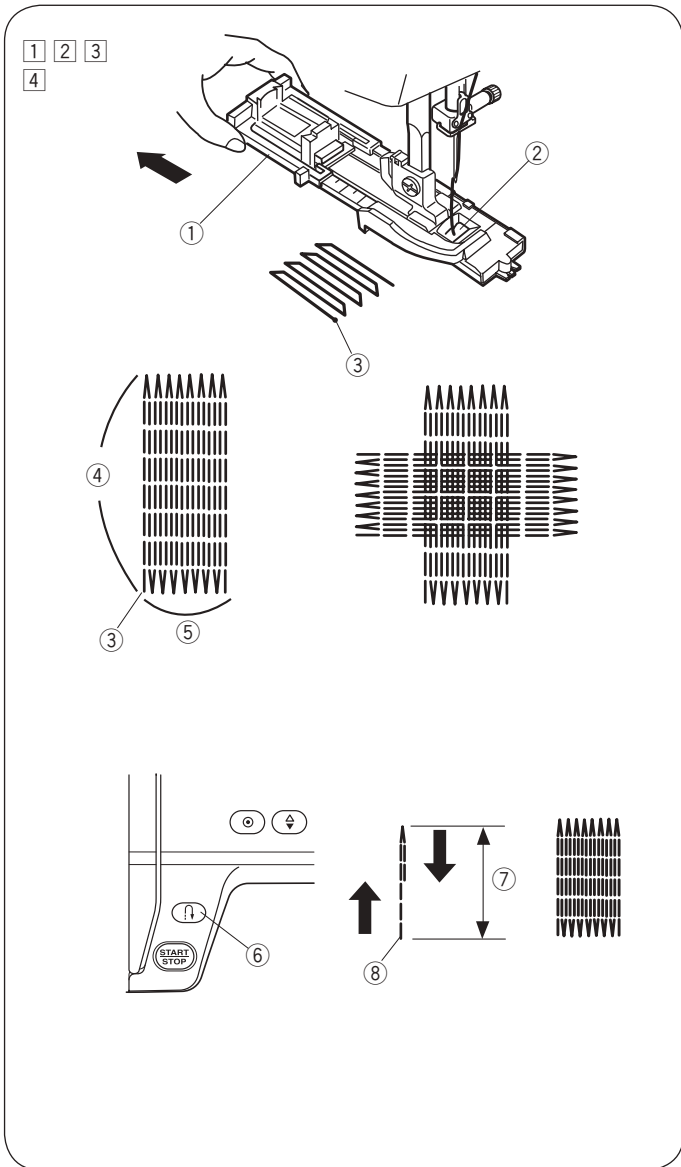

### • Starting to sew

- ① Pull the button holder ① to the back.
- ② Place the garment under the foot. Press the needle up/down button twice. Move the fabric to the left to draw both threads under the foot.
- ③ Lower the foot and start the machine.  
The machine will lock stitch, sew 16 rows of darning, lock stitch again and stop automatically.
- ④ Turn the fabric and repeat sewing.
  - ① Button holder
  - ② Hole
  - ③ Starting point
  - ④ 3/4" (2 cm)
  - ⑤ 9/32" (0.7 cm)

### • Sewing a shorter darning

To sew a darning shorter than 3/4" (2 cm), first stop the machine after sewing the required length ⑦, then press the reverse stitch button ⑥.

The required length ⑦ has been determined.

Start the machine again and continue sewing until the machine stops automatically.

- ⑥ Reverse stitch button
- ⑦ Required length
- ⑧ Starting point

### • Sewing a same-sized darning

Simply start the machine to sew another darning at the same size.

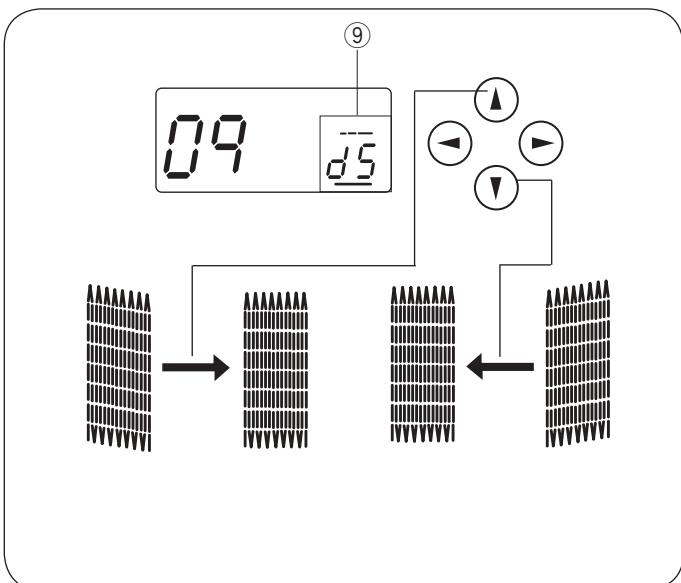

### • Adjusting the evenness of the darning

Correct the evenness of the darning as follows:

Press the cursor buttons ◀ ▶ to move the cursor under the value "d5" ⑨ (default setting).

When the right side of the darn is lower than the left side, press the ▲ button to set the value to "d6" – "d9", and make the darn even.

When the left side of the darn is lower than the right side, press the ▼ button to set the value to "d1" – "d4", and make the darn even.

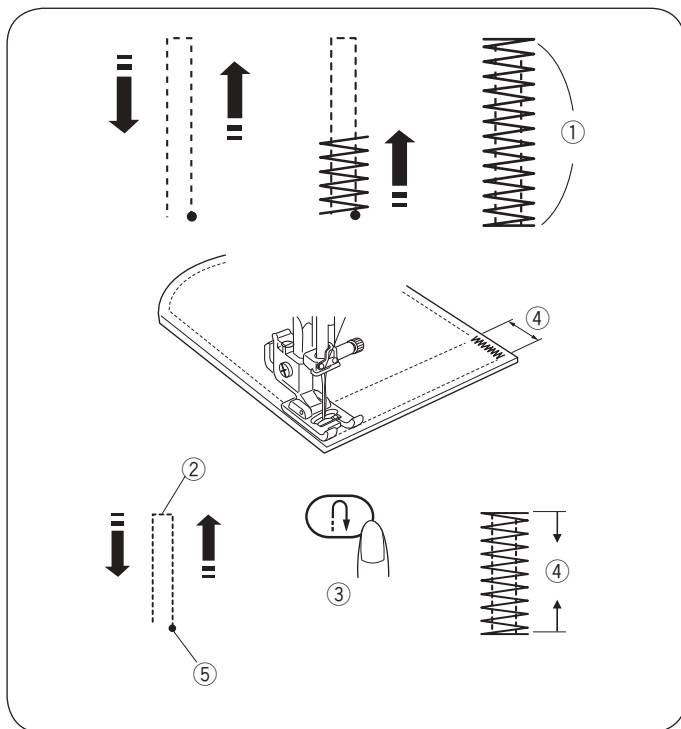
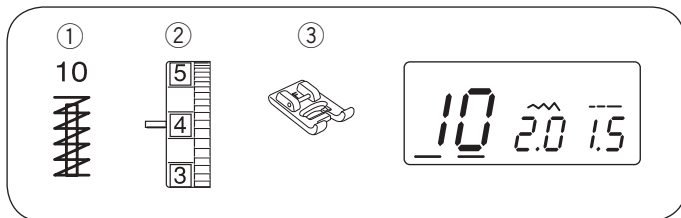

**Tacking**

- ① Stitch pattern: 10
- ② Thread tension dial: 3 to 6
- ③ Presser foot: Satin stitch foot F

Tacking is used to reinforce pockets, crotches and belt carriers where extra strength is needed.

**• Start sewing**

Start the machine and sew until the machine stops automatically. The machine will sew a tacking 1.5 cm (5/8") long.

- ① 1.5 cm (5/8")

**• Sewing a shorter tack**

\* Set the speed control slider at low speed setting.

To sew a tack shorter than 1.5 cm (5/8"), first stop the machine after sewing the required length ②, then press the reverse stitch button ③.

The tack length ④ has been determined.

Start the machine again and continue sewing until the machine stops automatically.

- ② Required length
- ③ Reverse stitch button
- ④ Tack length
- ⑤ Starting point

**• Sewing a same-size darning**

Simply start the machine to sew another tack at the same size.

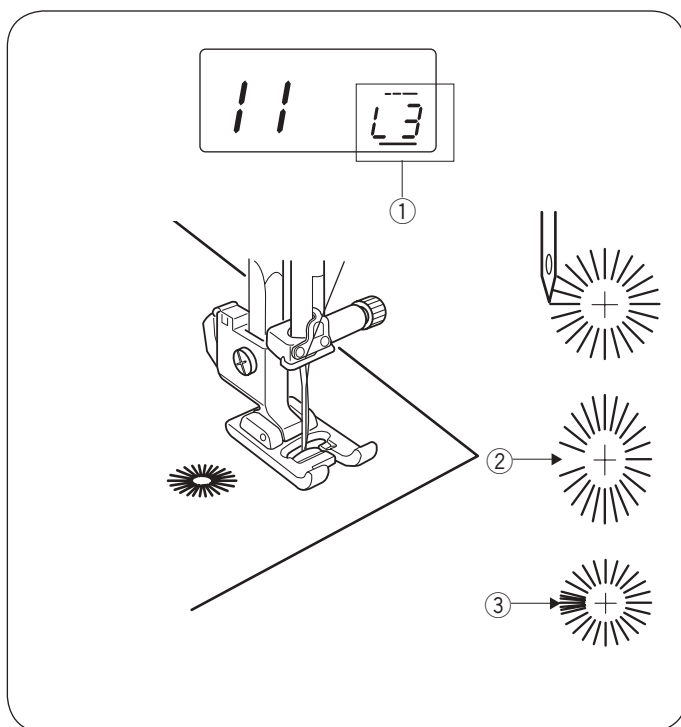
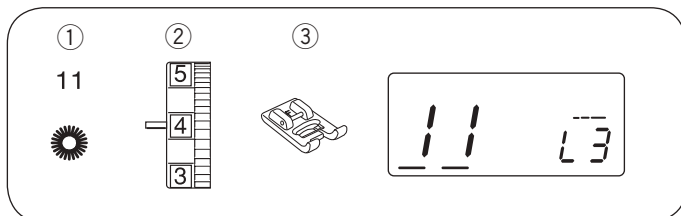

**Eyelet**

- ① Stitch pattern: 11
- ② Needle thread tension: 1 to 4
- ③ Presser foot: Satin stitch foot F

The eyelet is used for belt holes etc.

**• Starting to sew**

Attach the satin stitch foot F.

Start the machine. The machine will stop automatically when completed.

Open the eyelet with an awl, eyelet punch or pointed scissors.

**• Adjusting the shape of an eyelet**

Correct the shape of the eyelet as follows:

Press the cursor buttons ◀ ▶ to move the cursor under the value "L3" (default setting) ①.

If the eyelet gap opens ②, press the ▼ button to make the darn even. (L1~L2)

If the eyelet overlaps ③, press the ▲ button to make the darn even. (L4~L5)

**NOTE:**  
The shape can be adjusted within L1 to L5 (default setting is L3).

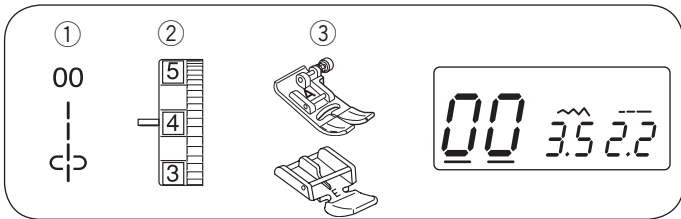

## Zipper Sewing

- ① Stitch pattern: 00
- ② Needle thread tension: 1 to 4
- ③ Presser foot: Zigzag foot A  
Zipper foot E

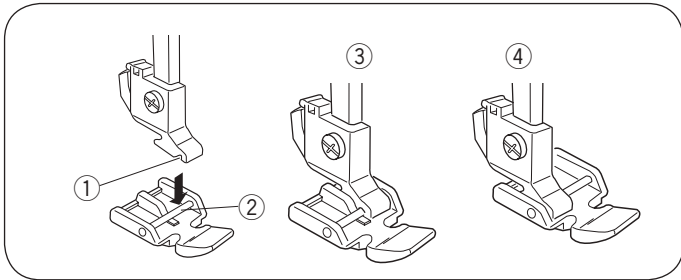

- Attaching the zipper foot  
Fit the pin on the zipper foot into the groove in the foot holder.
- To sew the left side of the zipper, attach zipper foot with the right-hand side of pin.
- To sew the right-side of zipper, attach zipper foot with the left-hand side of pin.
  - ① Slit
  - ② Pin
  - ③ To sew left side
  - ④ To sew right side

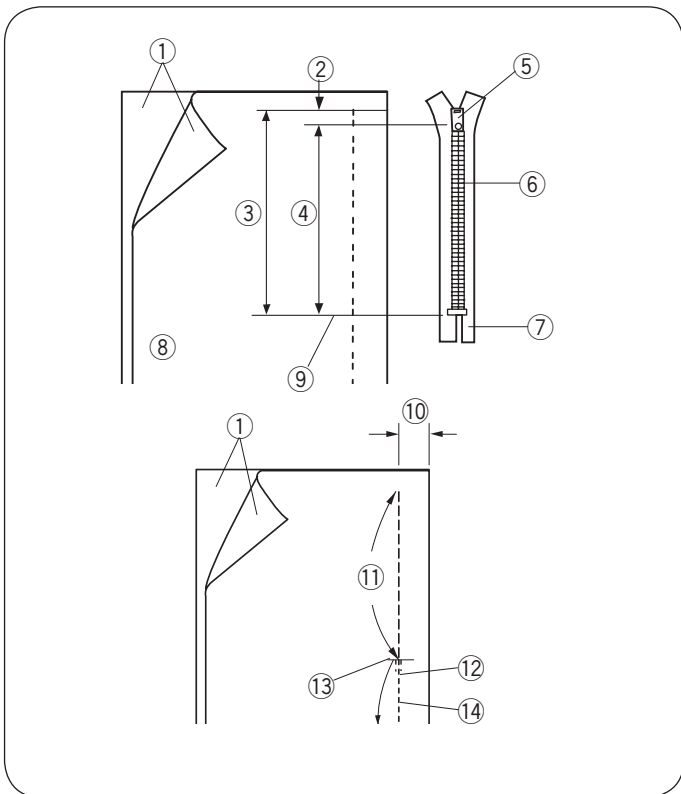

### • Fabric preparation

Add 3/8" (1 cm) to the zipper length. This is the overall opening size.

- ① Right side of the fabric
- ② 3/8" (1 cm)
- ③ Opening size
- ④ Zipper length
- ⑤ Slider
- ⑥ Zipper teeth
- ⑦ Zipper tape
- ⑧ Wrong side of the fabric
- ⑨ End of the opening

Place the right sides of the fabric together and sew up to the end of the zipper opening, with a 13/16" (2 cm) seam allowance. Reverse the stitch to fasten the seam. Attach the zigzag foot. Baste along the zipper opening with the stitch length 4.5.

- ⑩ 13/16" (2 cm)
- ⑪ Zipper opening (Basting)
- ⑫ Reverse stitches
- ⑬ End of the opening
- ⑭ Seam

### NOTE:

Loosen the thread tension to one (1) for basting.

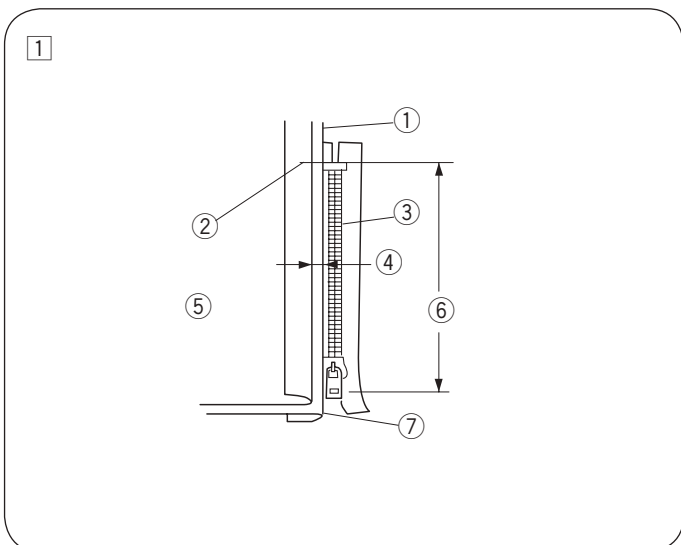

### • Start sewing

① Fold up the upper seam allowance. Fold back the bottom seam allowance to form a 1/8" (0.3 cm) fold. Place the zipper teeth next to the fold and pin it in place.

- ① Bottom fabric
- ② End of the zipper opening
- ③ Zipper teeth
- ④ 1/8" (0.3 cm)
- ⑤ Wrong side of the upper fabric
- ⑥ Opening size
- ⑦ Fold

## Zipper Sewing (continued)

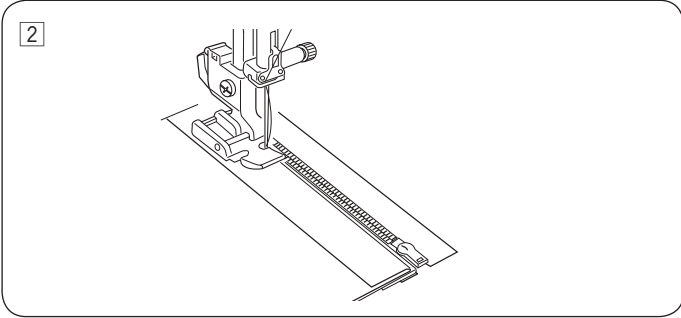

- 2 Attach the zipper foot with the pin on the right. Sew through all the layers from the end of the zipper opening, guiding the zipper teeth along the edge of the foot.

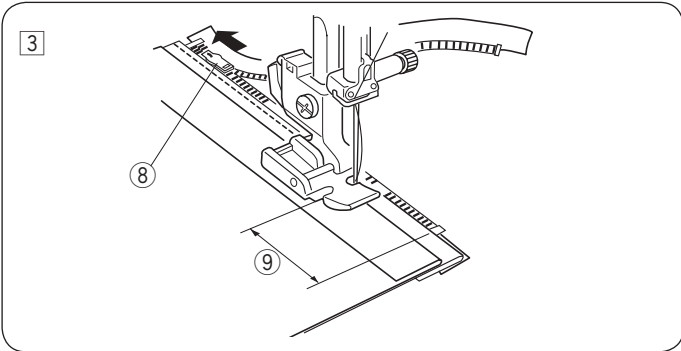

- 3 Stop the machine 2" (5 cm) before the foot reaches the slider on the zipper tape. Lower the needle into the fabric, and raise the foot. Open the zipper, then lower the foot and stitch the remainder of the seam.

- 8 Slider
- 9 2" (5 cm)

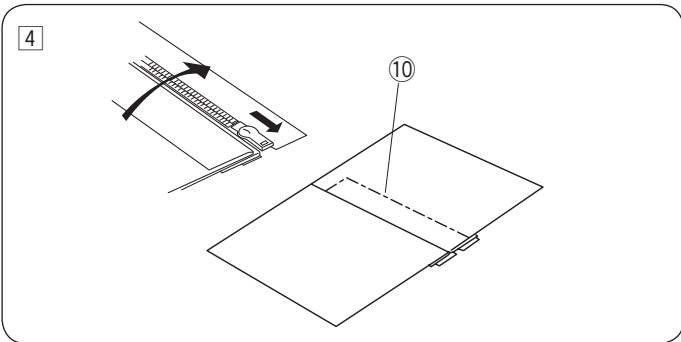

- 4 Close the zipper and open the upper fabric flat over the zipper. Baste the upper fabric and zipper tape together.

- 10 Basting stitch

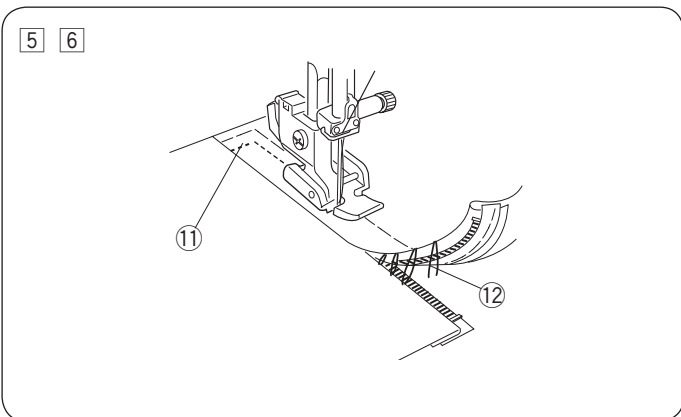

- 5 Detach the foot and attach it with the pin on the left. Backstitch across the end of opening 3/8" (1 cm). Turn the fabric 90 degrees and stitch through the garment and zipper tape.

- 11 Backstitch

- 6 Stop the machine 2" (5 cm) before the foot reaches the slider on the zipper tape. Lower the needle into the fabric, and raise the foot. Remove the basting stitches.

- 12 Basting stitches

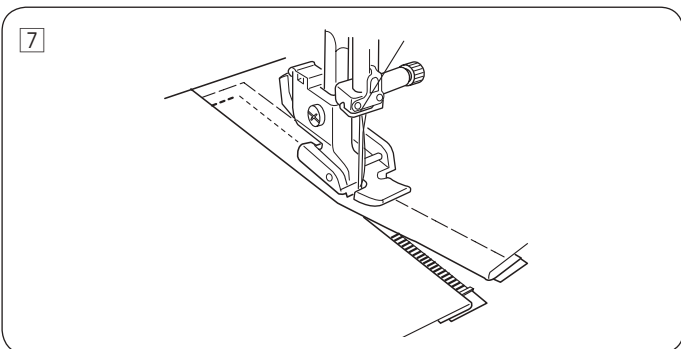

- 7 Open the zipper, then lower the foot and stitch the remainder of the seam. After finished sewing, remove the basting stitches on the upper fabric.

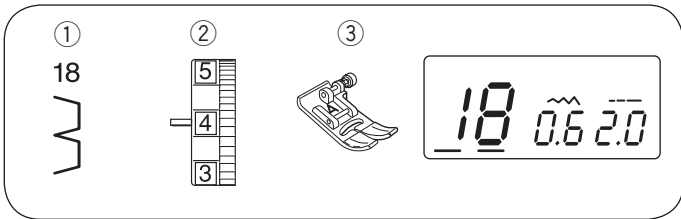

### Blind Hemming

- ① Stitch pattern: 18
- ② Thread tension dial: 1 to 4
- ③ Presser foot: Zigzag foot A

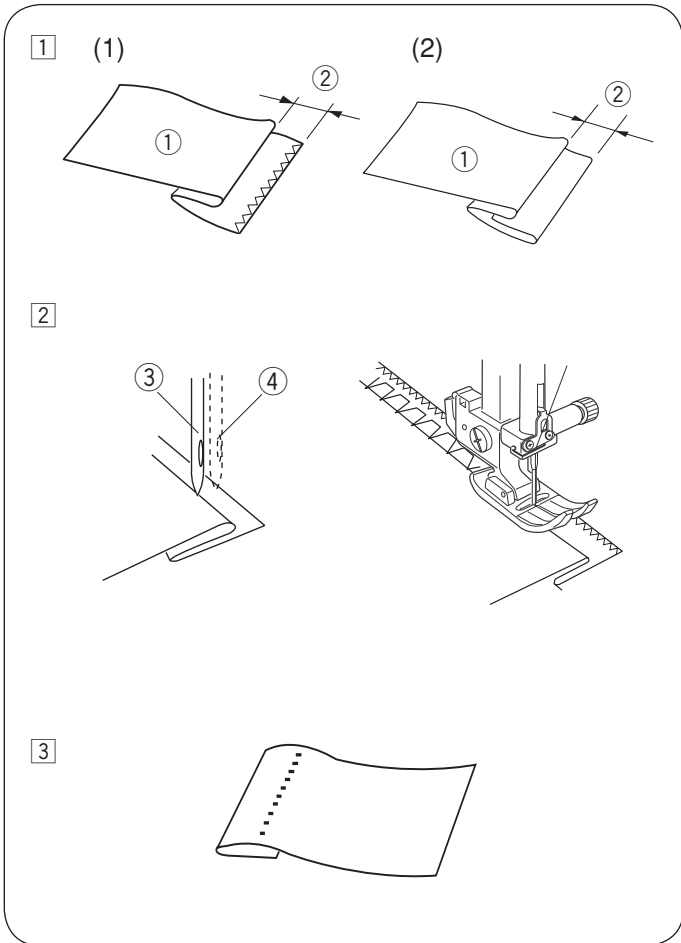

- 1 Fold a hem with the wrong side of the fabric up to form a 1/4" – 7/16" (0.4 – 0.7 cm) allowance.
  - ① Wrong side of fabric
  - ② 1/4" – 7/16" (0.4 – 0.7 cm)
  - (1) On heavyweight fabrics that tend to ravel, the raw edge should be overcast first.
  - (2) Fold the hem under the fabric for lightweight fabrics.
- 2 Position the fabric, so that the needle at its leftmost position just pierces the edge of the fold.
  - ③ When the needle comes to the left
  - ④ When the needle comes to the right
- 3 Open the fabric after sewing is finished.

**NOTE:**

If the needle pierces too far left, the stitch will show through on the right side of the fabric.

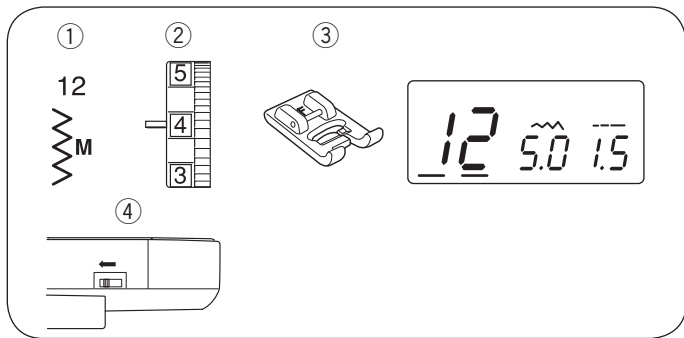

### Button Sewing

- ① Stitch pattern: 12
- ② Needle thread tension: 3 to 7
- ③ Presser foot: Satin stitch foot F
- ④ Feed dog: Dropped

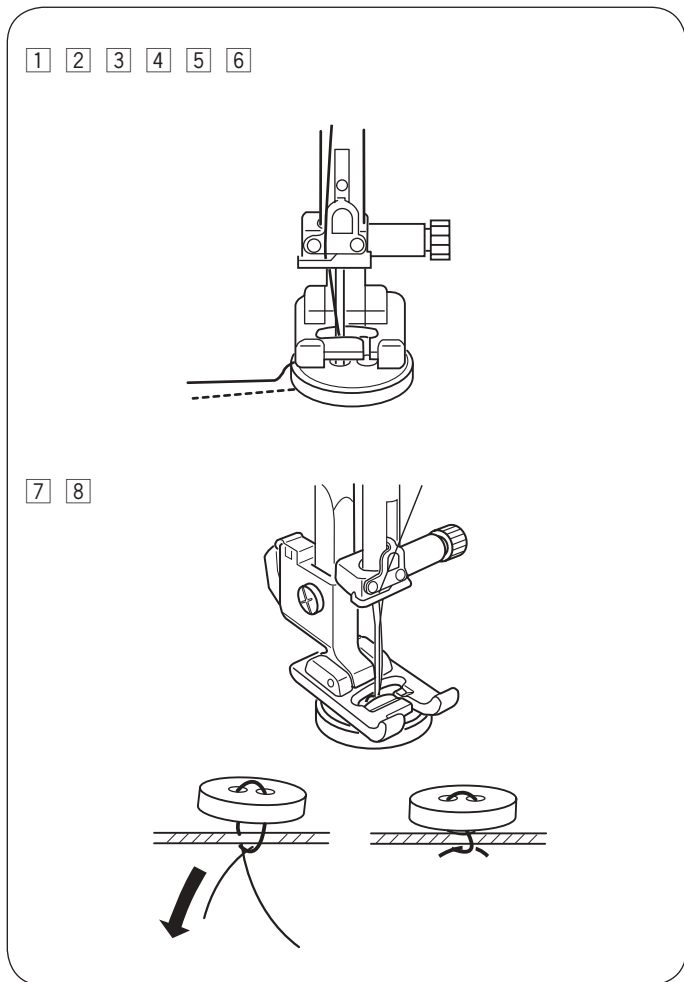

- ① Lower the feed dog.
- ② Match the holes of button to the horizontal slot on the presser foot.
- ③ Lower the foot to hold the button in place.
- ④ Adjust the stitch width so the needle will enter the left hole of the button.
- ⑤ Turn the handwheel so that the needle will enter the right hole of the button. Readjust the stitch width if necessary.
- ⑥ Stitch several times.

- ⑦ After you finish sewing, cut the thread but leave 3" to 4" of thread at the button.
- ⑧ With a hand sewing needle, draw the top thread to the reverse side of the fabric and knot the threads.

\* After the button sewing is completed, raise the feed dogs for normal sewing.

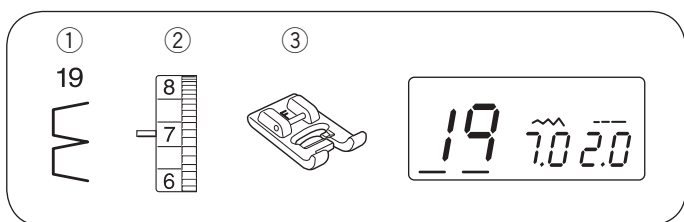

### Shelltuck Stitch

- ① Stitch pattern: 19
- ② Needle thread tension: 6 to 8
- ③ Presser foot: Satin stitch foot F

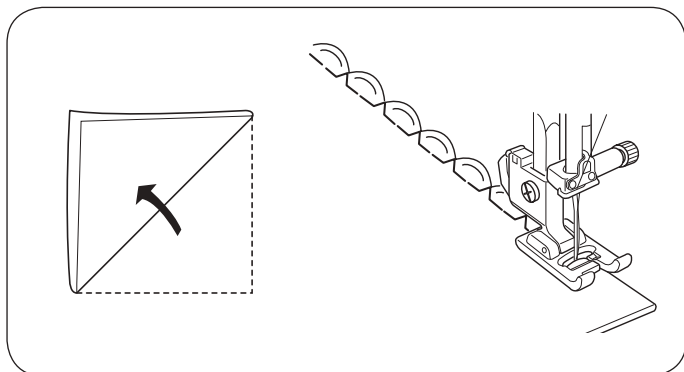

Use a lightweight fabric (tricot, for example). Fold the fabric as shown and stitch on the fold. Allow the needle to just clear the folded edge to create a shelled edge. You may need to increase the needle thread tension slightly. If you sew rows of shell stitches, space the rows at least 5/8" (1.5 cm) apart. You can also sew shell stitches on knits or soft silky woven fabrics, in any direction.

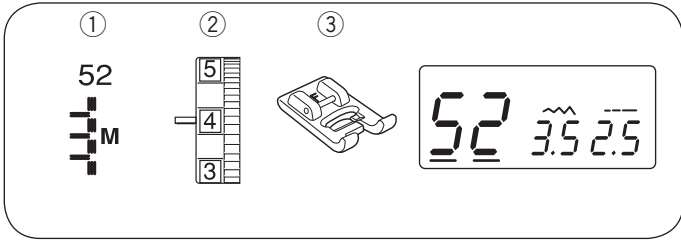

### Applique

- ① Stitch pattern: 52
  - ② Needle thread tension: 1 to 4
  - ③ Presser foot: Satin stitch foot F
- \* Stitch patterns 53 - 57 can be used.

Place an applique on the fabric and baste or pin it in place.

Reduce the foot pressure.

Sew while guiding the fabric so the needle falls along the outer edge of the applique.

- ① Applique
- ② Outer edge

When turning around a corner, stop the machine with the needle at the outer edge of applique.

Raise the presser foot and pivot the fabric around the needle to change the sewing direction.

### • To adjust the stitch width

Select pattern 52.

Press the cursor buttons (◀ ▶) to move the cursor under the stitch width value "3.5" ③ (default setting).

Press the (▼) button to decrease the stitch width ④.

Press the (▲) button to increase the stitch width ⑤.

The stitch width will be varied based on the centered needle drop position ⑥.

- ③ Stitch width (3.5)
- ④ Stitch pattern 52 (stitch width decreased)
- ⑤ Stitch pattern 52 (stitch width increased)
- ⑥ Center needle drop position

(A) The stitch pattern 56 has a fixed left needle drop position. When you change the stitch width, the right needle drop position will change.

(B) The stitch patterns 52, 53 and 54 have a fixed center needle drop position. The stitch width changes symmetrically.

(C) The stitch patterns 55 and 57 have a fixed right needle drop position. When you change the stitch width, the left needle drop position will change.

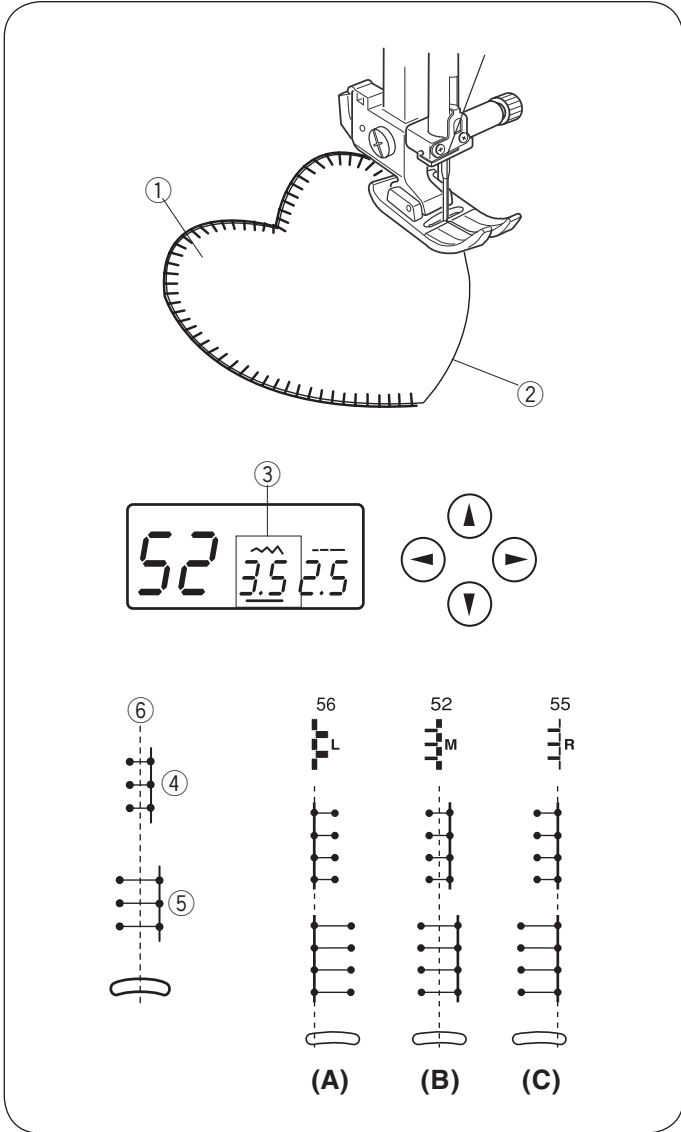

## SECTION IV. DECORATIVE STITCHING

### Scallop Stitch

- ① Stitch pattern: 28
- ② Thread tension dial: 3 to 6
- ③ Presser foot: Zigzag foot A

Sew the stitches approximately 3/8" (1 cm) inside the edge of the fabric.

Trim the outside of the stitches as shown. Make sure you don't cut the thread.

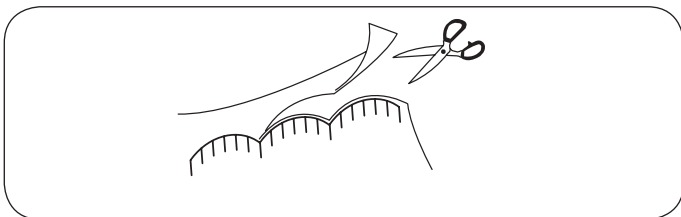
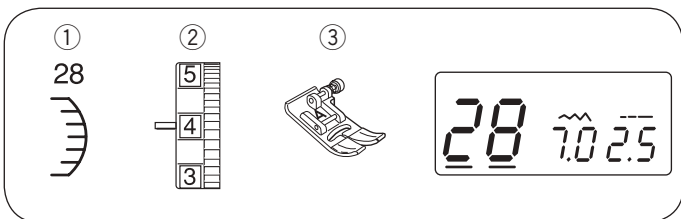

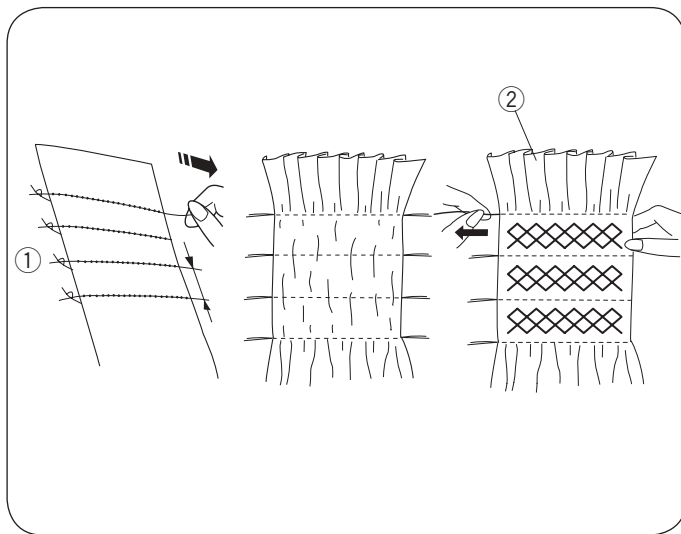
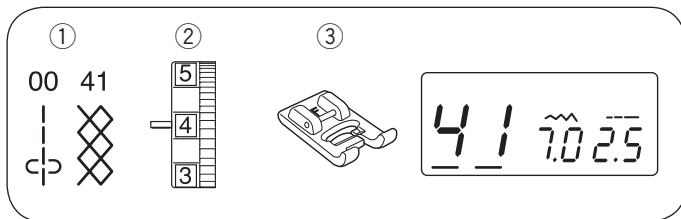

### Smocking

- ① Stitch pattern: 00 and 41
- ② Thread tension dial: 3 to 6
- ③ Presser foot: Satin stitch foot F

Smocking is a delicate decorative treatment used on children's clothes or women's blouses. Choose a soft and lightweight fabric such as batiste, gingham or challis. Cut the fabric three times wider than the projected width. Set stitch length at "5.0" and sew rows of straight stitches 3/8" (1.0 cm) apart across the area to be smocked.

#### NOTE:

Pull up the bobbin thread and draw a 4"-6" thread tail to the back before start sewing.

Knot the threads along one edge ①. From the other edge, pull the bobbin threads (bottom threads) to distribute the gathers ② evenly. Sew the smocking stitches between the gathered rows. Remove the straight stitches by pulling them out.

- ① Knotted edge
- ② Gathers

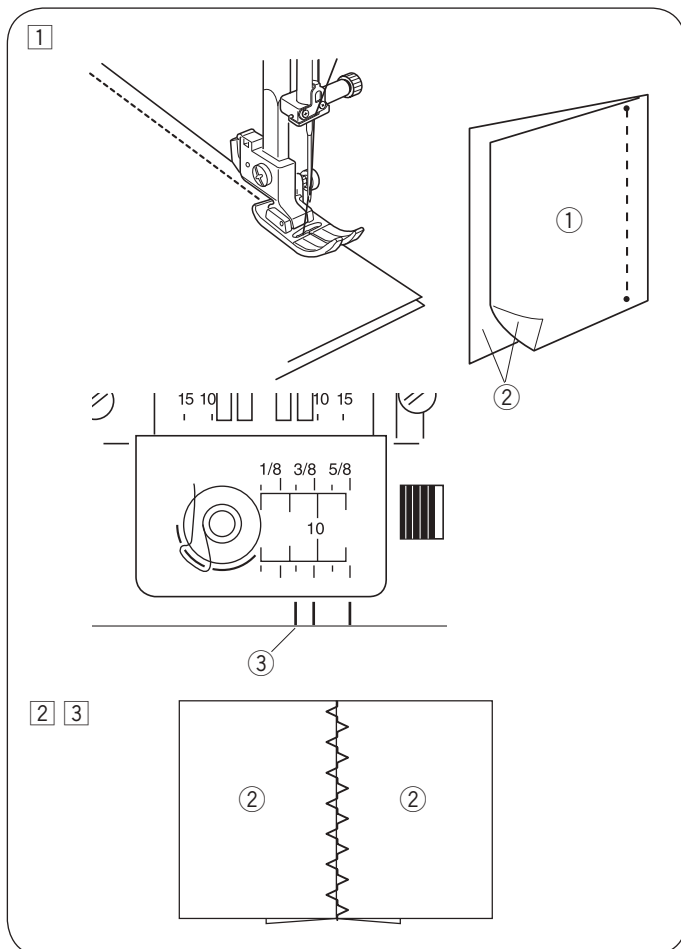
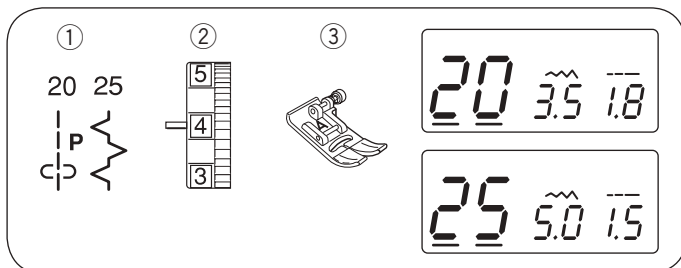

### Patchwork Piecing

- ① Stitch pattern: 20 and 25
- ② Thread tension dial: 3 to 6
- ③ Presser foot: Zigzag foot A

① Place the patchwork pieces right sides together. Select stitch pattern 20. Align the edges of the fabrics to the 1/4" front seam guide ③. Sew a precise 1/4" seam allowance.

- ① Wrong side of fabric
- ② Right side of fabric
- ③ Front seam guide (1/4")

② Select stitch pattern 25.

③ Press the seam allowance to open. Sew stitch pattern 25 on the right side of the garment centering over the seam line.

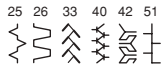
\* Stitch patterns 25, 26, 33, 40, 42, 51  can also be used.

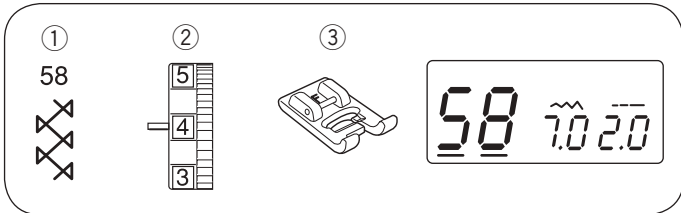

### Fagoting

- ① Stitch pattern: 58
- ② Thread tension dial: 3 to 6
- ③ Presser foot: Satin stitch foot F

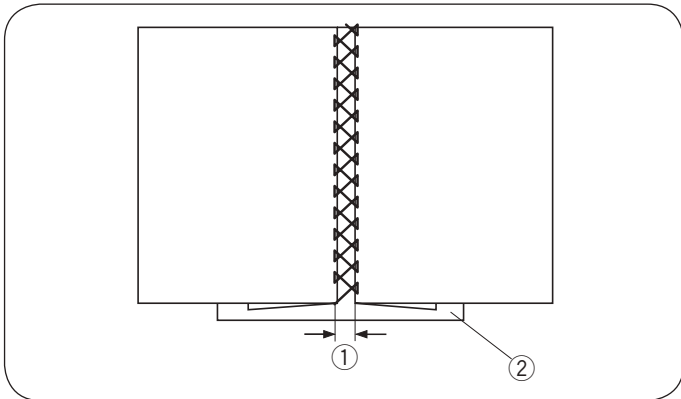

Use this stitch to join two pieces of fabric to create an open work appearance and add design interest.

Fold under each fabric edge 5/8" (1.5 cm) and press. Pin the two edges to paper or tear backing 1/8" apart. Sew slowly, guiding the fabric so the needle catches the folded edge on each side.

After finishing the sewing, take off the paper.

- ① 1/8" (0.3~0.4 cm)
- ② Paper

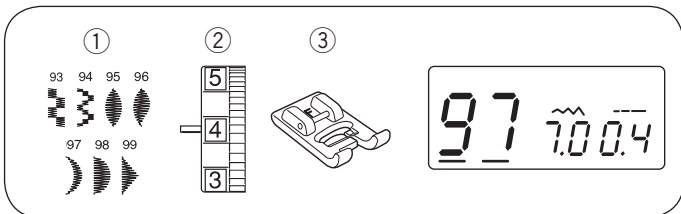

### Satin Stitches

- ① Stitch pattern: 97
- ② Thread tension dial: 3 to 6
- ③ Presser foot: Satin stitch foot F

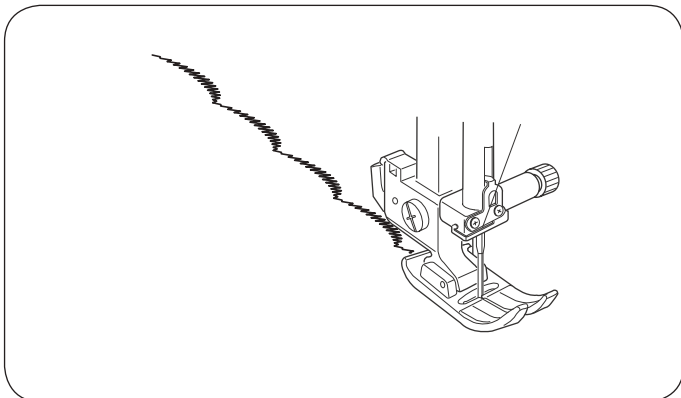

For better sewing results, interfacing should be used

on the wrong side of the fabric when you use stretch or elastic fabrics.

Press the auto-lock button to finish the end of the pattern.

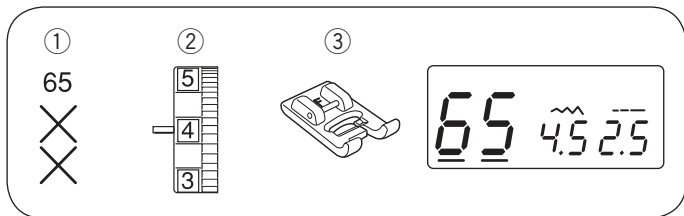

### Cross Stitch

- ① Stitch Pattern: 65
- ② Thread tension dial: 3 to 6
- ③ Presser foot: Satin stitch foot F

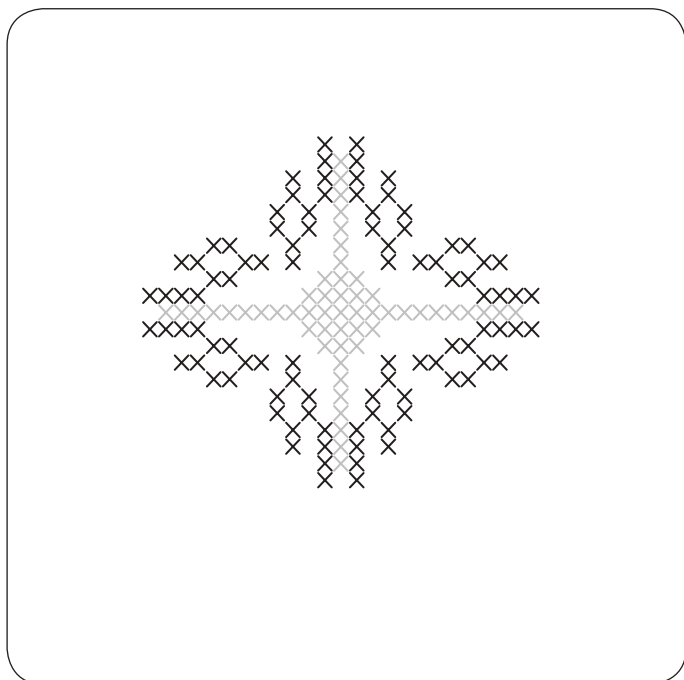

You can make cross stitch designs with these patterns, in half the time it would take if embroidered by hand.

\* If you press the auto-lock button before sewing, the machine will sew one unit of the cross stitch and stop automatically.

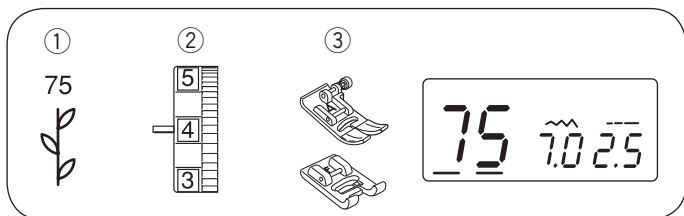

### Decorative Stitches

- ① Stitch Pattern: 75
- ② Thread tension dial: 3 to 6
- ③ Presser foot: Zigzag foot A  
Satin stitch foot F

\* Stitch patterns 24, 44~46, 64 and 70~92 can also be used.

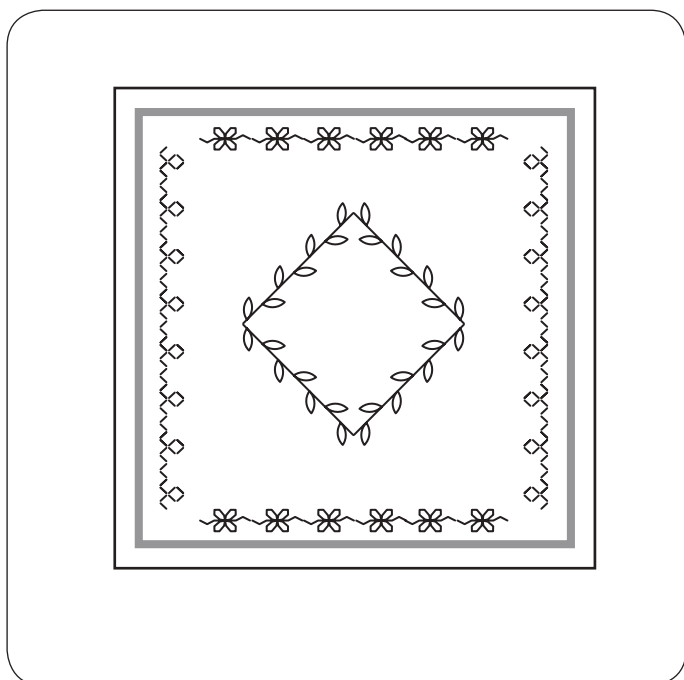

For the best sewing results, carefully align and guide the fabric when you sew with decorative stitches. Use a tear-way backing if necessary.

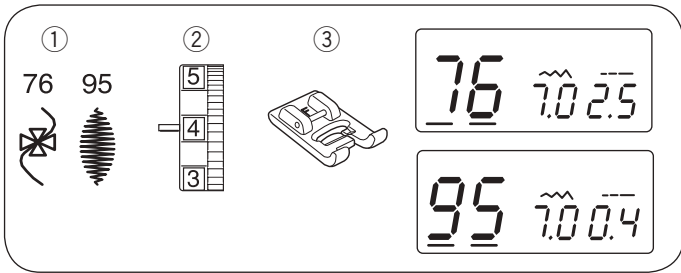

### Decorative Stitch Combinations

- ① Stitch Pattern: 76 and 95
- ② Thread tension dial: 3 to 6
- ③ Presser foot: Satin stitch foot F

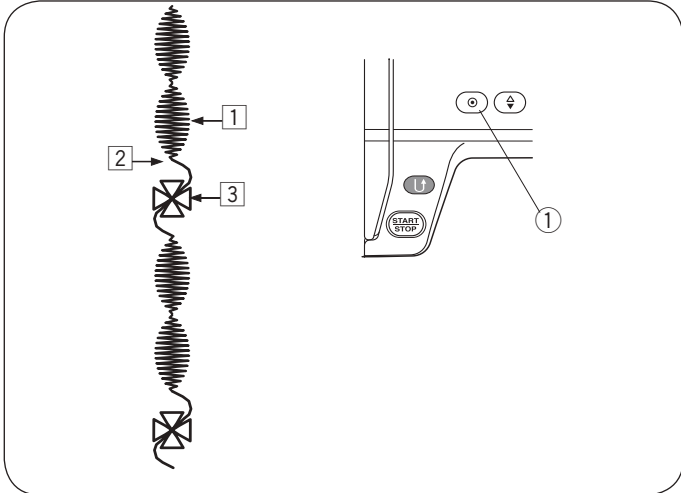

To combine two units of pattern 95 and 76.

- ① Sew pattern 95 and press the auto-lock button while sewing the second unit. The machine will stop automatically when the second unit is completed.
  - ① Auto-lock button
- ② Select stitch pattern 76. Press the auto-lock button and start sewing.
- ③ Machine will sew one unit of pattern 76 and stop automatically.
- ④ Repeat the procedure above.

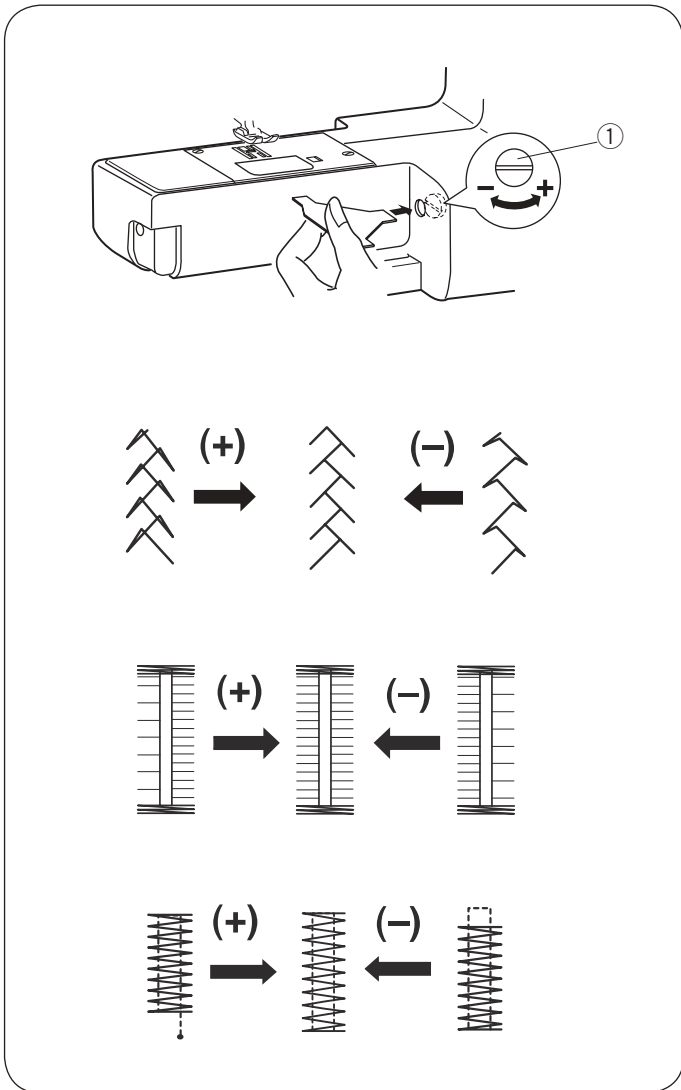

### Correcting Distorted Stitch Patterns

The sewing results of the stretch patterns may vary depending upon the sewing conditions, such as sewing speed, type of the fabric, number of layers etc. Always test sew on a scrap piece of the fabric that you wish to use.

If stretch patterns are distorted, correct it with the feed balancing dial.

- ① Feed balancing dial

#### Stretch stitch pattern

If the pattern is compressed, turn the feed balancing dial in the direction of “+”.

If the pattern is drawn out, turn the feed balancing dial in the direction of “-”.

#### Stitch balance of buttonholes

If the right row is denser, turn the feed balancing dial in the direction of “+”.

If the left row is denser, turn the feed balancing dial in the direction of “-”.

#### Evenness of tacking

If the stitch does not meet start position, turn the feed balancing dial in the direction of “+”.

If the stitch does not meet return position, turn the feed balancing dial in the direction of “-”.

## SECTION V. CARE OF YOUR MACHINE

### Cleaning the Hook Race and Feed Dog

#### **⚠️ WARNING:**

- Turn the power switch off and unplug the machine before cleaning.
- Do not dismantle the machine other than as explained in this section.

#### **⚠️ CAUTION:**

Do not store the machine in a high-humidity area, near a heat radiator, or in direct sunlight.

#### **NOTE:**

Clean the outside of the machine with a soft cloth and neutral soap.

After cleaning the machine, make sure the needle and presser foot are attached.

Press the needle up/down button to raise the needle, then unplug the sewing machine.

Remove the needle and presser foot.

Remove the cover plate by sliding the cover plate release button to the right. Take out the bobbin. Brush out dust and lint. (You may also use a vacuum cleaner.)

- 1 Remove the setscrews ② on the needle plate ③ with the screwdriver key ① supplied with the machine. Remove the needle plate ③.
- 2 Lift up the bobbin holder ⑤ and remove it.
- 3 Clean the bobbin holder ④ with a lint brush.
- 4 Clean the feed dog ⑥ and hook race ⑦ with the lint brush.
- 5 Clean the center of the hook race with a dry cloth.

- ① Screwdriver key
- ② Setscrews
- ③ Needle plate
- ④ Lint brush
- ⑤ Bobbin holder
- ⑥ Feed dog
- ⑦ Hook race

\* You may also use a vacuum cleaner.

\* The machine does not require oiling.



### Installing the Bobbin Holder

- 1 Insert the bobbin holder ① so that the knob ③ fits next to the stopper ② in the hook race.
- 2 Insert the bobbin.
- 3 Attach the needle plate with the setscrews ⑤. After cleaning the machine, make sure the needle and presser foot are attached.

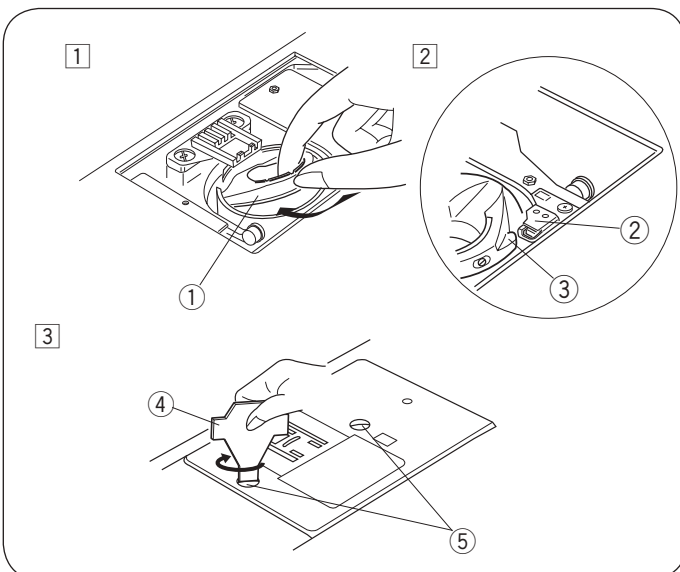
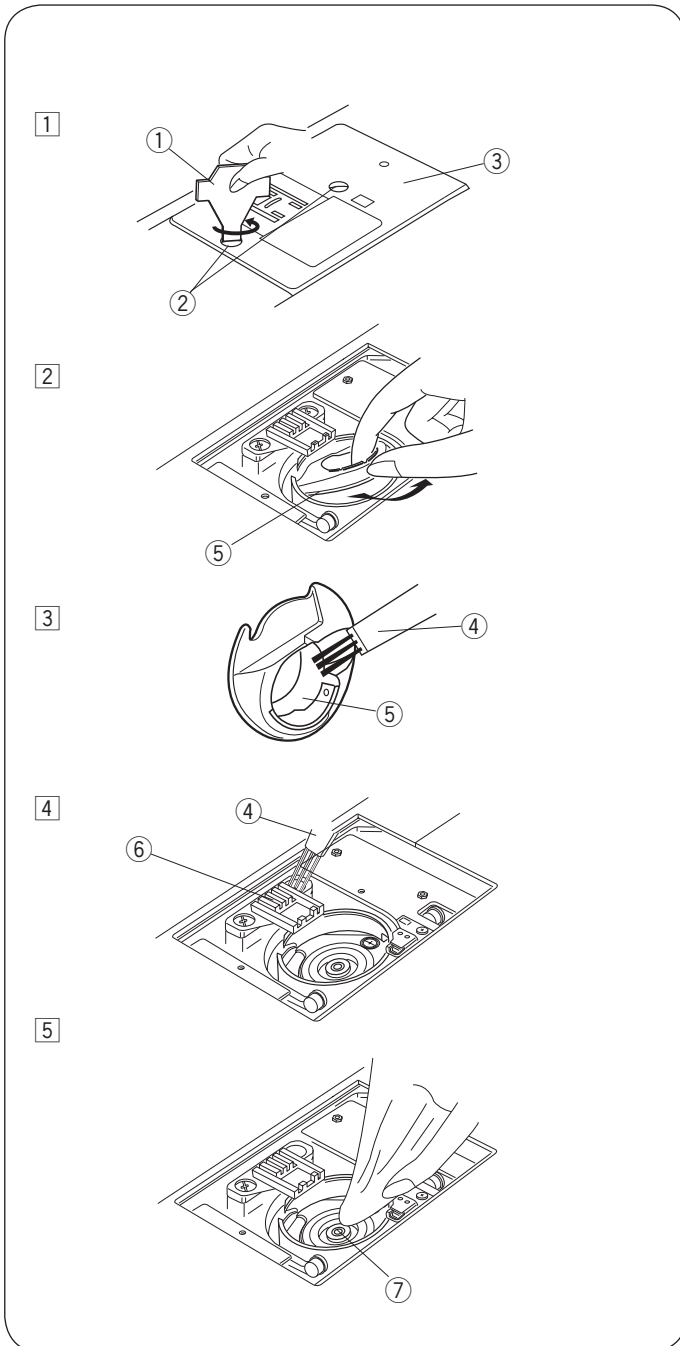
- ① Bobbin holder
- ② Stopper
- ③ Knob
- ④ Screwdriver key
- ⑤ Setscrews

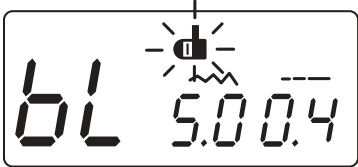

## Problems and Warning Signs

Warning sign	Cause	Try this
	The machine will not sew with the start/stop button because the foot control is connected.	Disconnect the foot control and start the machine.
	A buttonhole is sewn without lowering the buttonhole lever.	Lower the buttonhole lever and restart the machine.
	The bobbin winder spindle is moved to the right.	Move the bobbin winder spindle to the left.
	The machine is restarted too soon after it has halted due to the overload.	Wait for at least 15 seconds to restart. If threads are jamming, remove the jammed threads.

Audible signal	The buzzer sounds when:
Pip	Normal operation
Pip-pip-pip	Invalid operation
Pip-pip-peep	Buttonhole sewing completed
Peep	Malfunction

## Troubleshooting

Condition	Cause	Reference
The needle thread breaks.	<ol style="list-style-type: none"> <li>1. The needle thread is not threaded properly.</li> <li>2. The needle thread tension is too tight.</li> <li>3. The needle is bent or blunt.</li> <li>4. The needle is incorrectly inserted.</li> <li>5. The needle thread and the bobbin thread are not set under the presser foot when start sewing.</li> <li>6. The threads were not drawn to the rear after sewing.</li> <li>7. The thread is either too heavy or too fine for the needle.</li> </ol>	<p>See page 13, 14 See page 17, 18 See page 9 See page 9 See page 19 See page 19 See page 9</p>
The bobbin thread breaks.	<ol style="list-style-type: none"> <li>1. The bobbin thread is not threaded properly in the bobbin holder.</li> <li>2. Lint has collected in the bobbin holder.</li> <li>3. The bobbin is damaged and doesn't turn smoothly.</li> <li>4. The thread is wound loosely on a bobbin.</li> </ol>	<p>See page 12 See page 41 Replace the bobbin. See page 11</p>
The needle breaks.	<ol style="list-style-type: none"> <li>1. The needle is incorrectly inserted.</li> <li>2. The needle clamp screw is loose.</li> <li>3. The threads were not drawn to the rear after sewing.</li> <li>4. The needle is too fine for the fabric being used.</li> <li>5. The presser foot is not appropriate for the stitch pattern being sewn.</li> </ol>	<p>See page 9 See page 9 See page 19 See page 9 Change the presser foot.</p>
Skipped stitches	<ol style="list-style-type: none"> <li>1. The needle is incorrectly inserted, bent or blunt.</li> <li>2. The needle and/or threads are not suitable for the work being sewn.</li> <li>3. A Blue Tip needle is not being used for sewing stretch, very fine fabrics and synthetics.</li> <li>4. The needle thread is not threaded properly.</li> <li>5. A poor quality needle is used.</li> </ol>	<p>See page 9 See page 9 See page 9 See page 13, 14 Change the needle.</p>
Seam puckering	<ol style="list-style-type: none"> <li>1. The needle thread tension is too tight.</li> <li>2. The needle thread is not threaded properly.</li> <li>3. The needle is too heavy for the fabric being sewn.</li> <li>4. The stitch length is too long for the fabric.</li> </ol>	<p>See page 17, 18 See page 13 See page 9 Make the stitches shorter.</p>
The cloth is not feeding smoothly.	<ol style="list-style-type: none"> <li>1. The feed dog is packed with lint.</li> <li>2. The stitches are too fine.</li> <li>3. The feed dog is not raised after "drop feed" sewing.</li> </ol>	<p>See page 41 Make the stitches longer. See page 9</p>
Stitches form loops below the works.	<ol style="list-style-type: none"> <li>1. The needle thread tension is too loose.</li> <li>2. The needle is either too heavy or too fine for the thread.</li> </ol>	<p>See page 17, 18 See page 9</p>
The machine does not work.	<ol style="list-style-type: none"> <li>1. The machine is not plugged in.</li> <li>2. Thread has been caught in the hook race.</li> <li>3. The bobbin winder spindle is not returned to the left after bobbin winding.</li> </ol>	<p>See page 4 See page 41 See page 11</p>
Buttonhole sewing is not sewn properly.	<ol style="list-style-type: none"> <li>1. The stitch density is not suitable for the fabric being sewn.</li> <li>2. Suitable interface material has not been used for the stretch or synthetic fabric.</li> </ol>	<p>See page 28 Use an interfacing.</p>
The machine does not run smoothly and is noisy.	<ol style="list-style-type: none"> <li>1. Thread has been caught in the hook race.</li> <li>2. Lint has built up in the hook race or bobbin holder.</li> </ol>	<p>See page 41 See page 41</p>
Abnormal noise from the hook area and faulty stitches.	<ol style="list-style-type: none"> <li>1. The bobbin holder is worn or damaged.</li> </ol>	<p>Replace the bobbin holder.</p>





